

Trampolin brugermanual

ASG4475

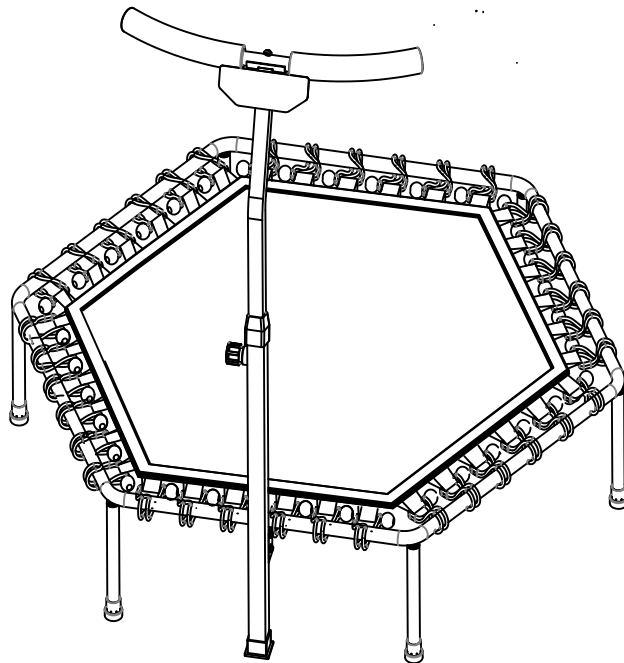

Hvis noget er beskadiget eller mistet ved modtagelse, bedes du kontakte os for at få det erstattet. Vi håber du bliver glad for dit køb.

INDHOLD

Advarsler.....	3-4
Liste over trampolindele.....	5-6
Monteringsvejledning.....	7-14
Vedligeholdelse.....	15
Garanti.....	16

Bemærk:

Kontroller venligst delene i forhold til dellisten før montering. Hvis der mangler eller er beskadigede dele, bedes du kontakte kundeservice for udskiftning.

Advarsler

! DANGER



INGEN FLIPS



**Kun én bruger ad gangen.
Maksimal vægt: 100 kg**



**MÅ IKKE
BRUGES, hvis du
er kommet til
skade**



**Fjern alle hårde
eller skarpe
genstande, før du
hopper**



**MÅ IKKE BRUGES
ved graviditet**

Daglig inspektion før brug

- > Kontroller om benene er skruet fast eller revnet.
- > Kontroller om elastiksnørerne er løse eller beskadigede.
- > Kontroller om måtten og syningerne er revnede.
- > Kontroller om rammen er snoet eller revnet.

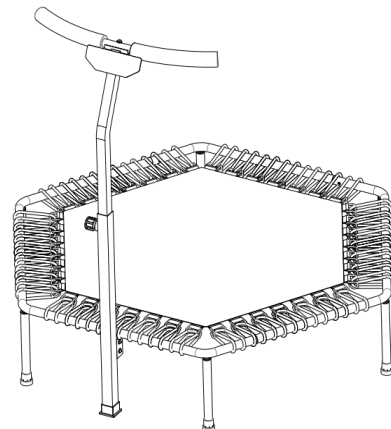

Advarsler - Brugsanvisning

Læs disse instruktioner og advarsler omhyggeligt, og sørg for altid at følge dem. Følg alle monterings- og vedligeholdelsesinstruktioner nøje for at sikre, at udstyret er sikkert og holder så længe som muligt.







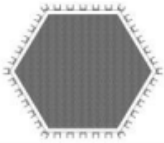

- Du skal læse manualen grundigt inden montering.
- Kontakt din læge, før du begynder at træne. Hvis du oplever svimmelhed, kvalme, bryst smerter, rygsmerter eller andre unormale symptomer, skal du STOPPE din træning og KONTAKTE EN LÆGE OMGÅENDE, før du fortsætter.
- Den maksimale vægtgrænse (installer 36 elastiksnore) er 100 kg.
- Tillad ikke mere end én person på trampolinen ad gangen. Risiko for kollision.
- Tillad ikke små børn at bruge trampolinen, medmindre de er under opsyn af en voksen.
- Det er ejerens ansvar at sikre, at alle, der bruger trampolinen, er fuldt ud bekendt med alle advarsler og sikkerhedsinstruktioner.
- Dette produkt er beregnet til brug af voksne og teenagere. Hold øje med børn under 6 år.
- Spis ikke, mens du hopper.

Advarsler - installationsvejledning

- Tillad ikke mere end én person på trampolinen. Ellers kan det resultere i alvorlige skader.
- Undgå at hoppe for højt. Hold dig lavt, indtil du har kontrol over hoppet, og land altid i midten af trampolinen. Kontrol er vigtigst, når du hopper.
- Sørg for, at alle dele, inklusive benene, er korrekt monteret, før du bruger trampolinen.
- Tilstrækkelig frihøjde over hovedet er afgørende. Minimum 3 meter fra jorden til toppen. Væk fra ledninger, loftsventilatorer og andre mulige farer.
- Placer trampolinen væk fra vægge, strukturer, møbler og andre legeområder. Sørg for en fri plads på 1,8 meter på alle sider af trampolinen.
- Fjern alle genstande under trampolinen.
- Brug ikke trampolinen i mørke. Kunstig belysning kan være nødvendig.
- Stop med at hoppe ved at bøje knæene, når fødderne kommer i kontakt med trampolinmatten. Lær denne færdighed først.
- Kun til indendørs brug.

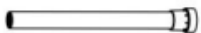
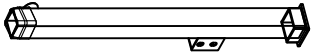
Liste over trampolindele









Liste 1

Key Number	Part Picture	Description	Quantity
A		T6-Jump Mat	1
B		U-Frame Part	1
C		L-Frame Part	4
D		I-Frame Part	1
E		Leg with Cap	6
F		Handrail Leg	1
G		Handrail Support Rod	1
H		Handrail bar with Foam	1
I		Nameplate part	1

Bemærkning: Denne trampolin kan leveres med en ekstra elastiksnor til udskiftning

Liste over trampolindele

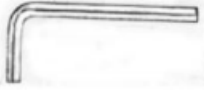
Liste 2

Key Number	Part Picture	Description	Quantity
1		Bungee	36
2		Adjustable Knob	1
3		D8-Flat Washer	3
4		D6-Flat Washer	2
5		M8X12 Screws	5
6		M6X12 Screws	8
7		Leg Socket Cap (Pre-assembled with #E)	6
8		Hex Key Wrench	1
9		Triangle Tool	1

Hvis dele mangler eller er beskadigede, bedes du kontakte os.

Monteringsvejledning

En eller flere stærke voksne er påkrævet for at installere denne trampolin. Husk altid at holde ansigtet væk fra skinnerne. Hvis du ikke gør det, kan skinnerne springe tilbage og forårsage skade. Installer venligst rammen, før du installerer elastikkerne!
!!!Advarsel: Vær opmærksom på installationsrækkefølgen for rammetilbehøret, læs instruktionerne omhyggeligt, eller se installationsvideoen før installation.

Trin 1 - Installer rammen

1. Læg #B-U-rammedelen på et åbent gulv i den vinkel, der er vist på figuren.
2. Installer fire #C-L-rammedele i rækkefølge som vist på figuren.
3. Installer #D-I-rammedelen på rammen som vist på figuren for at danne en færdig ramme.
4. Brug en #8-unbrakonøgle til at montere #6 M6X12-skruer på rammen for at fastgøre den.

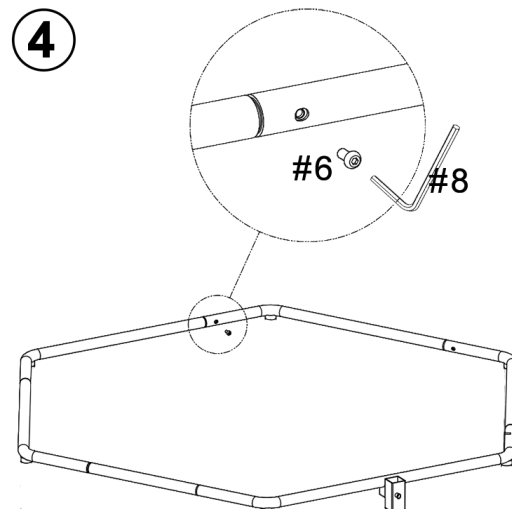
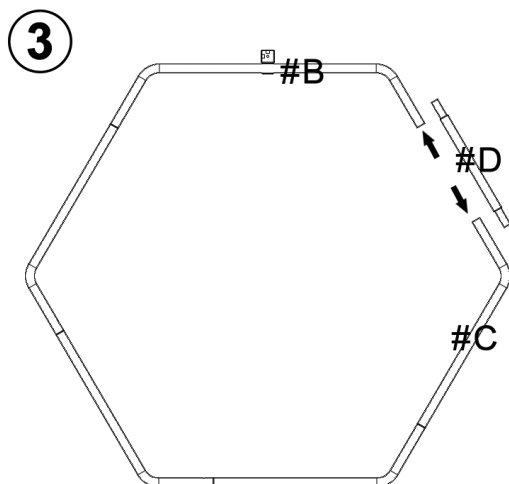
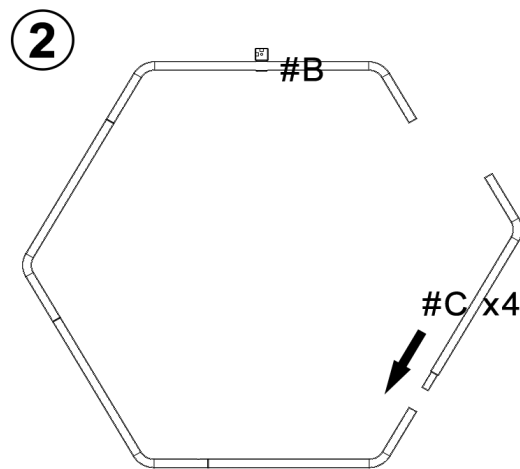
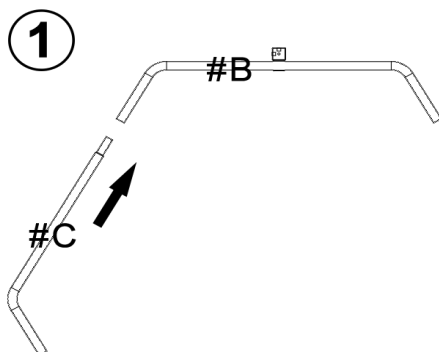

Monteringsvejledning

Trin 2 - Fastgør elastikerne

1. Sørg for, at metalringen er i den sorte metalspænde, før du monterer #1-Bungees.
2. Sæt den smalle ende af #9-Trekantværktøjet i elastiksnoren.
3. Træk den smalle ende af #9-Trekantværktøjet tilbage, indtil den brede ende er låst fast i den sorte metalspænde.
4. Skub den smalle ende af #9-Trekantværktøjet mod måtten, indtil elastiksnoren klikker fast i den sorte metalspænde.

!!!Obs!!!: Sørg for, at rammen er helt fastgjort, inden du monterer elastikkerne.

①



②



③



④



Monteringsvejledning

Trin 3 - Installer hoppemåtten

Trampolinen leveres med 36 elastikstropper, og du kan installere dem efter behov. (Det anbefales at installere 36 elastikstropper i alt.) Hvis du har brug for mere detaljerede instruktioner om installation af elastiksnore, kan du se den relaterede video via linket.

> Forstå venligst installationsrækkefølgen for elastikkerne, inden du starter installationen, så bliver det nemmere at installere dem i den rækkefølge.

1. Sæt elastikkerne på den første metalspænde på hver side, og monter derefter elastikkerne på 6-bensforbindelsen eller i henhold til tallene markeret i figur 2 for at fastgøre hoppedugen.

2. Monter elastikkerne på den 3. metalspænde på hver side i rækkefølge som vist på billede 3.

3. Monter derefter alle elastikkerne.

!!!Obs!!!: Sørg for, at rammen er helt fastgjort, inden du monterer elastikkerne.

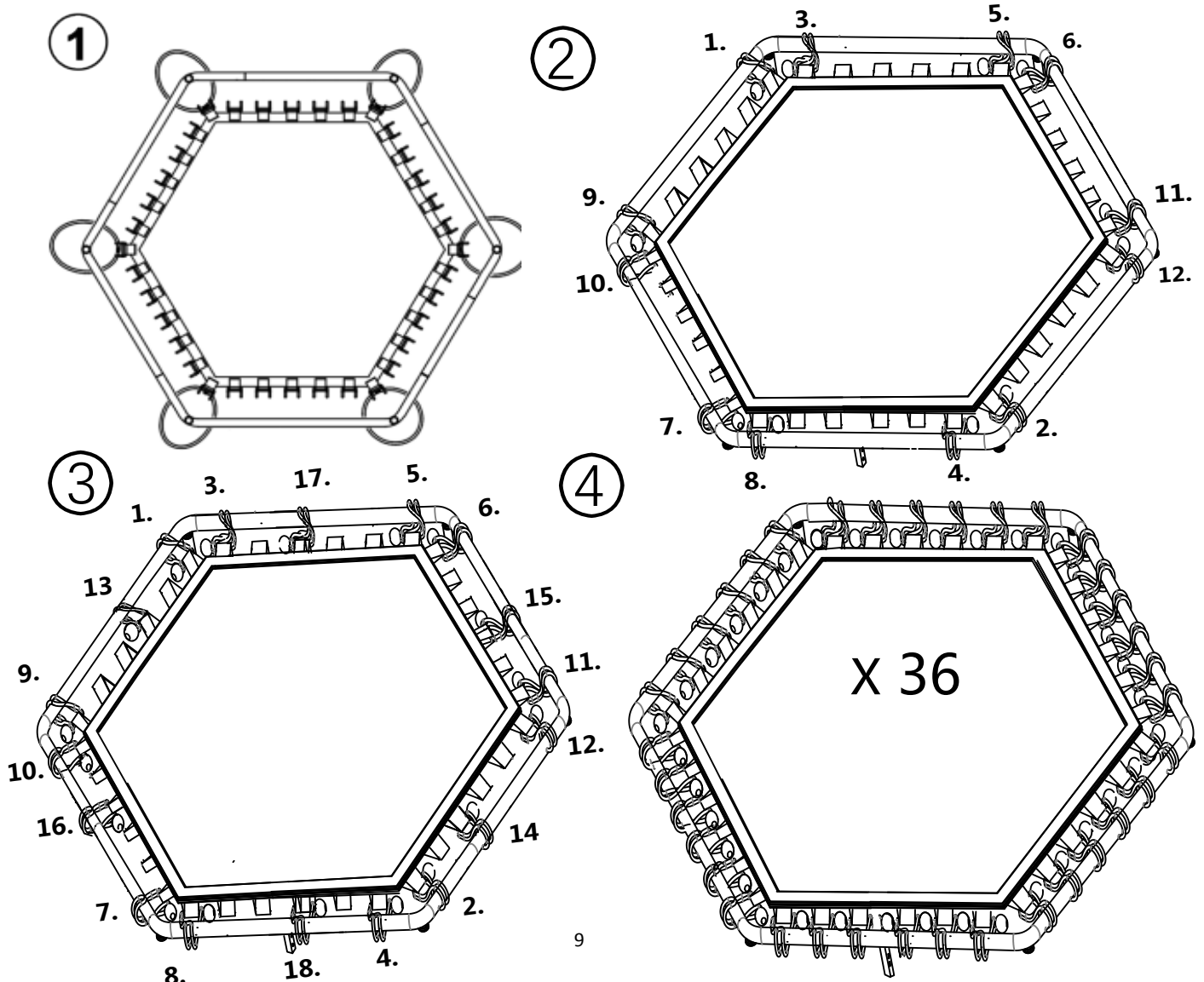

Monteringsvejledning

Trin 4 - Fastgør benet til rammen

> Fjern alle beskyttende endekapper fra skruegevindene og kasser dem. Sæt #E-benet på trampolinen benfatning, og drej det med uret, indtil det er helt fastspændt.

> #11-Skivepuder bruges til at justere benenes niveau. Hvis trampolinen ikke er helt i vater, kan du placere skiverne i gummifødderne for at justere niveauet.

!!!Obs!!!: Alle ben og benkapper skal være skruet fast. Trampolinen skal placeres fladt på jorden for at undgå slingren.

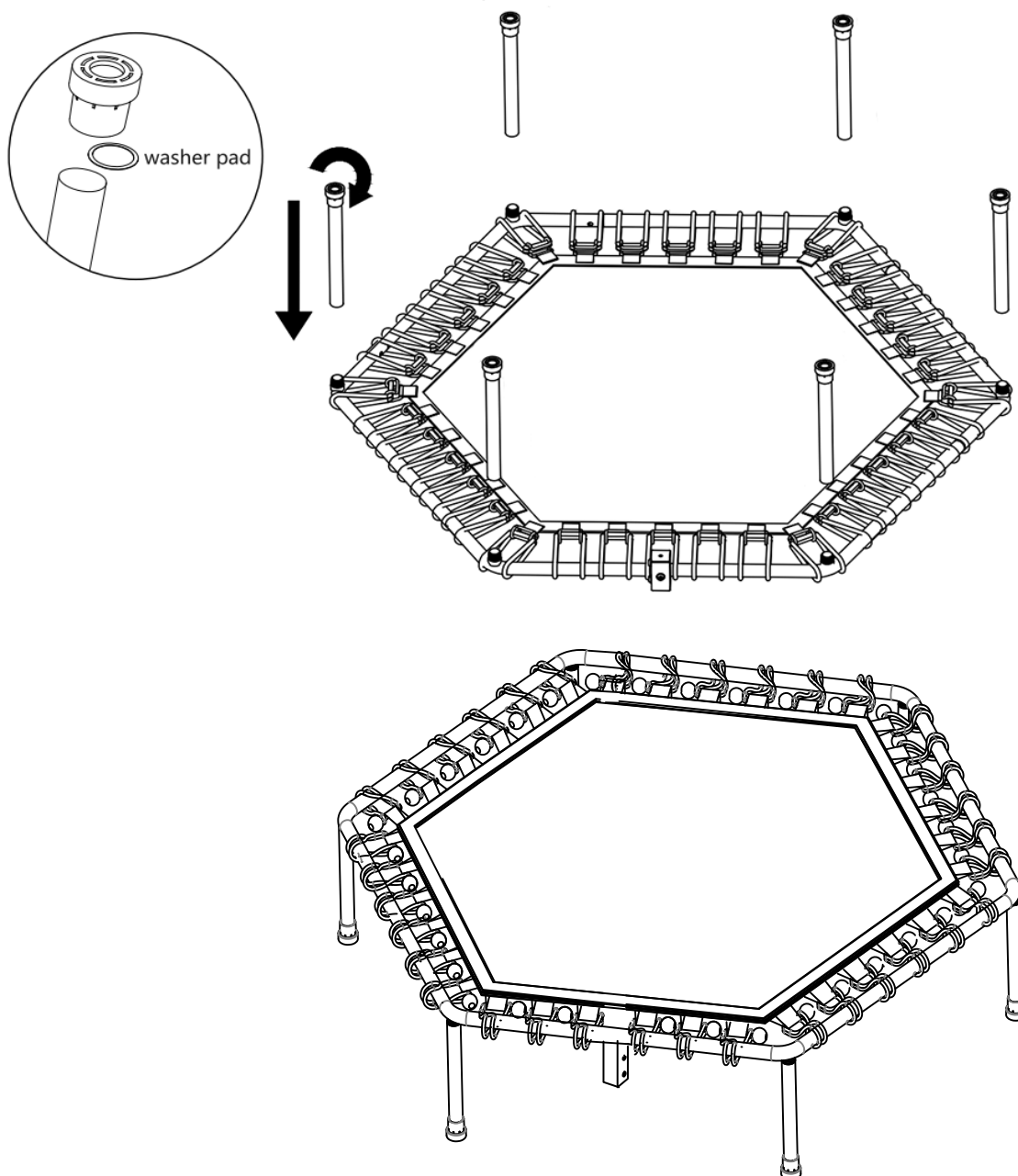

Monteringsvejledning

Trin 5 - Saml styret

- > Sæt #F- Gelænderbenet i forbindelsesstykket. Bemærk venligst, at de tre huller skal være justeret. Skru derefter #5- M8X12-skruer og #3- D8-flad skive med #8- unbrakonøgle for at fastgøre gelænderbenet.

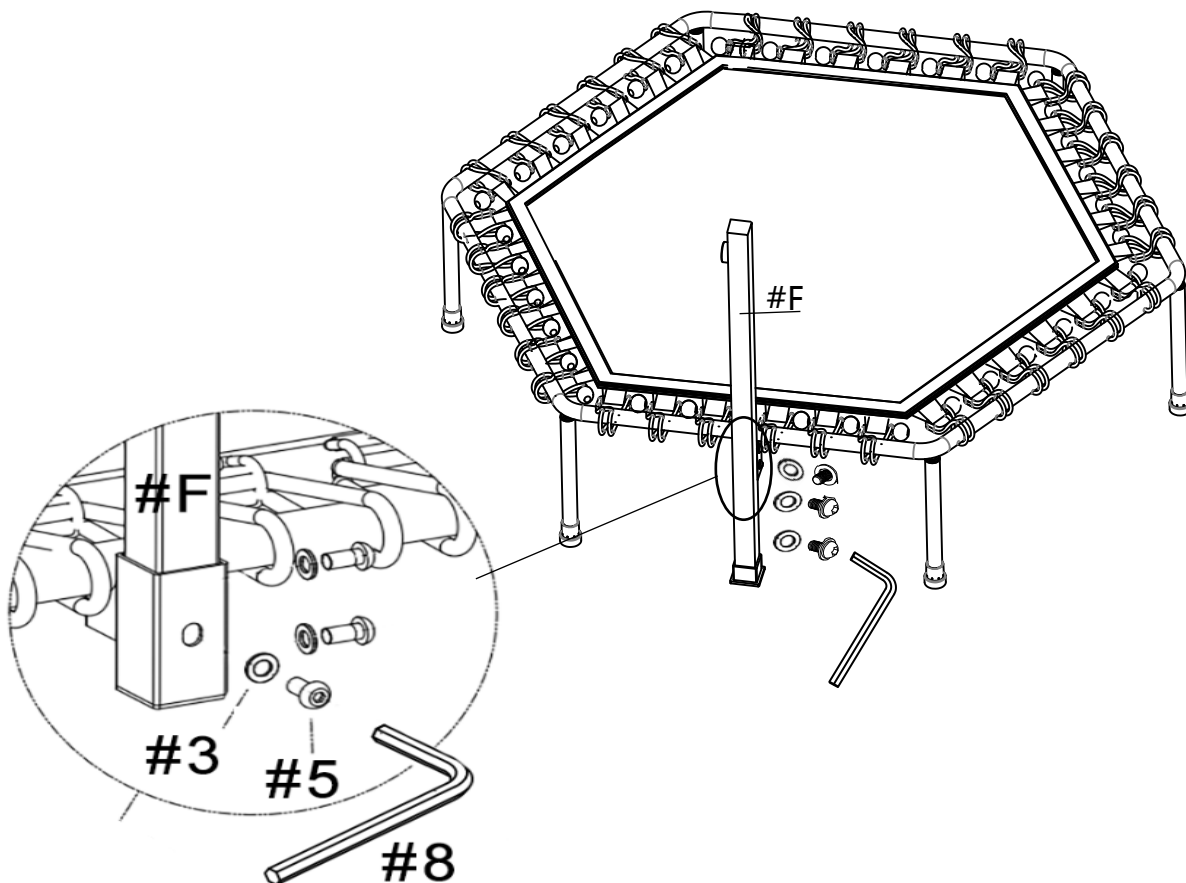

Monteringsvejledning

- > Sæt #G- Gelænderstøttestangen i #F- Gelænderbenet, juster hullets position i henhold til højden, og stram derefter #2- Justerbar knap.

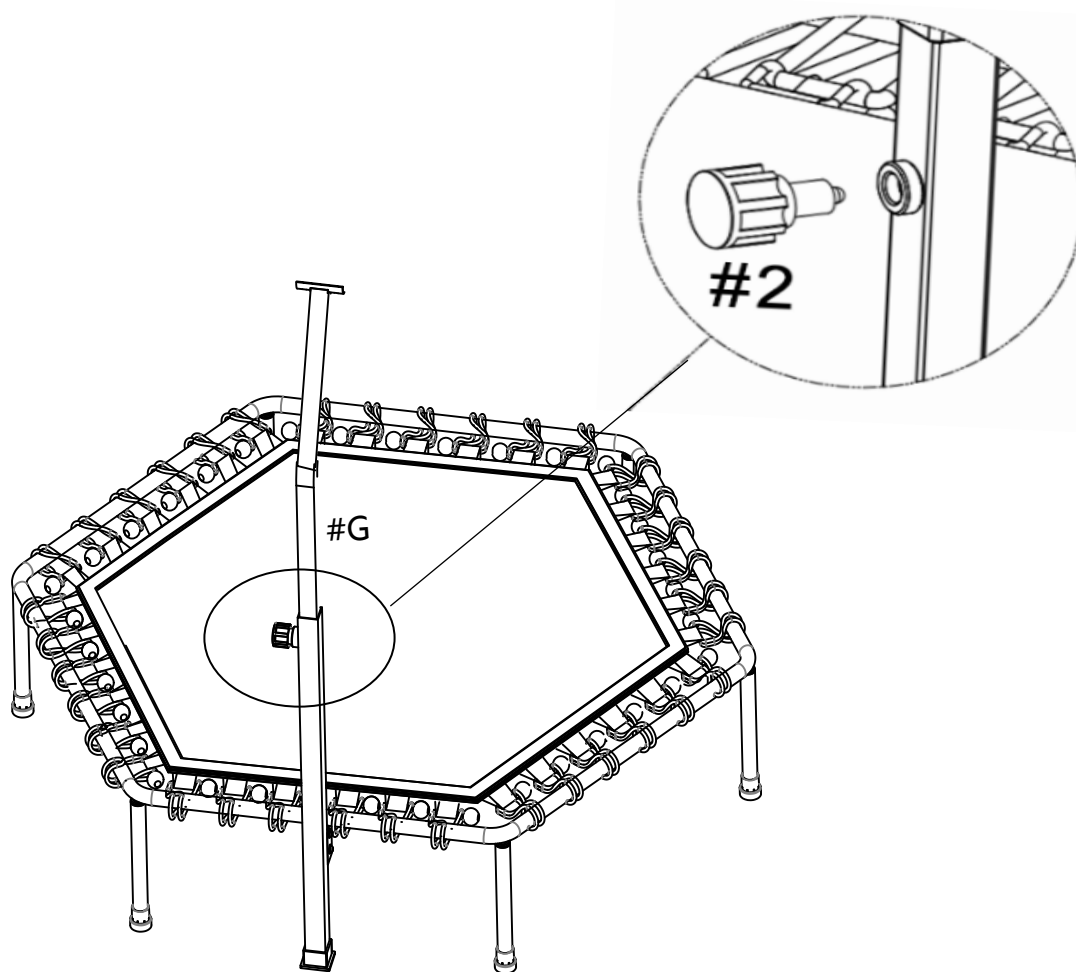

Monteringsvejledning

> Fastgør #H- Gelænderstang med skum til #G- Gelænderstøttestang, og monter derefter #5-M8X12-skruer med #8- Unbrakonøgle.

> Fastgør #I- Navneskilt del med håndtag, og monter derefter #6- M6X12-skruer og #4- D6-Flad skive med #8- Unbrakonøgle.

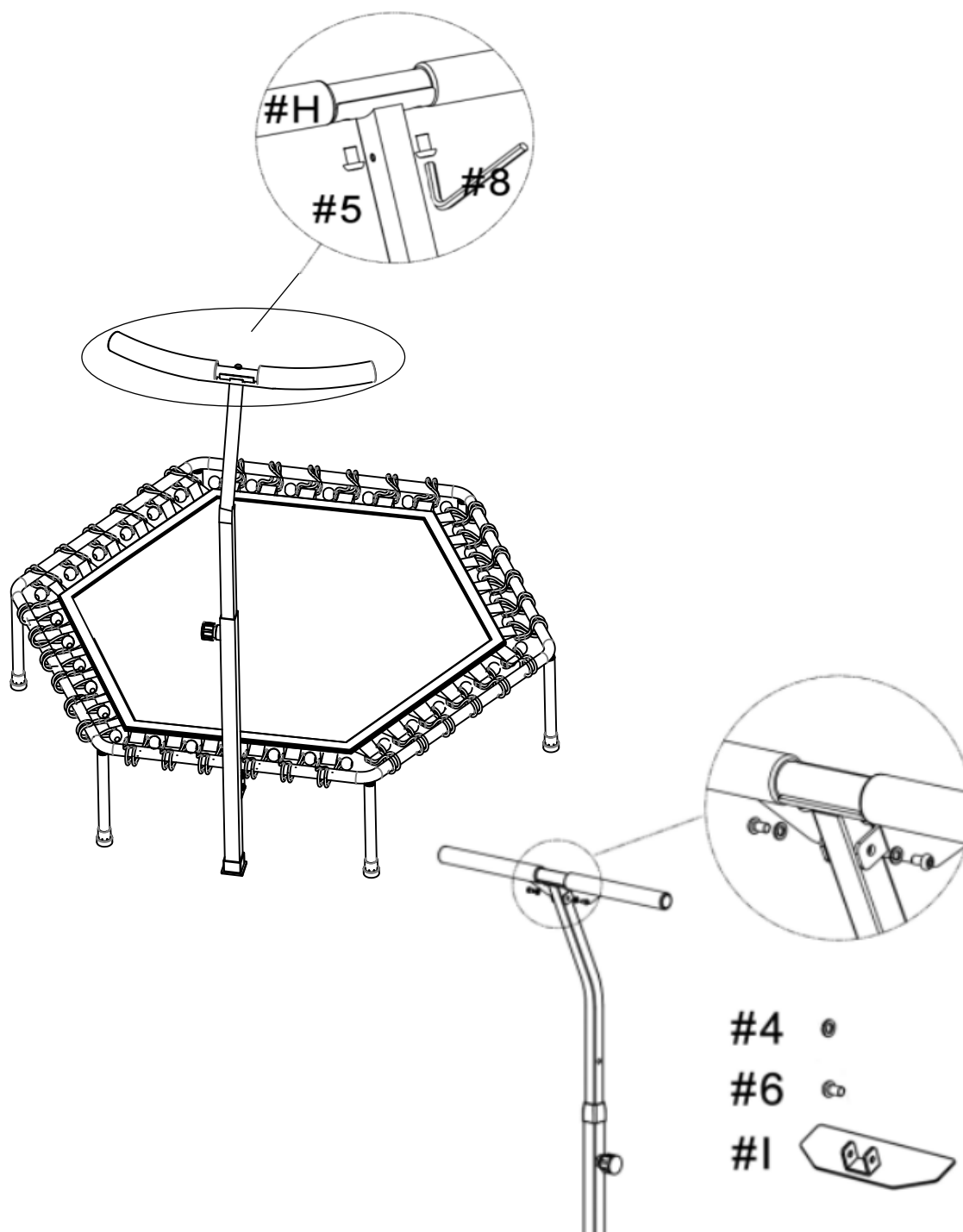

Monteringsvejledning

> Når trampolinen er fuldt installeret, kan du nyde trampolinens fornøjelse.

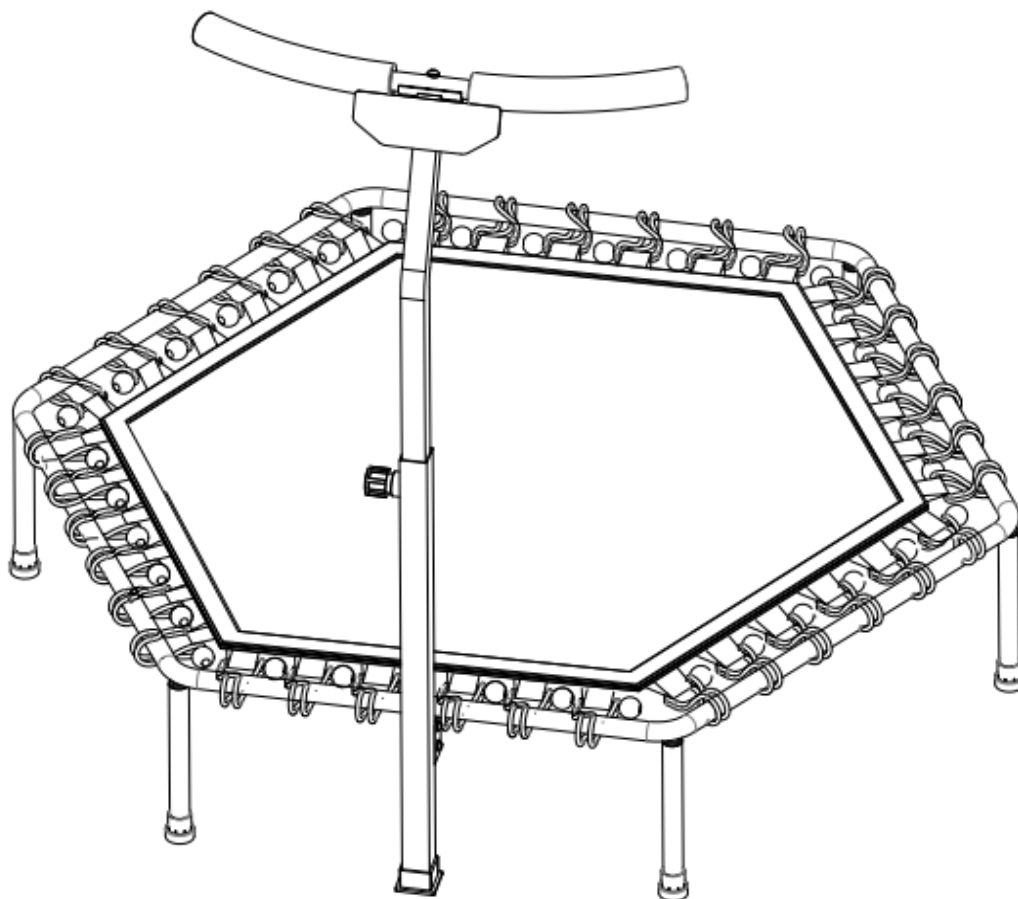

Vedligeholdelse



Manglende overholdelse af disse instruktioner eller korrekt betjening kan føre til alvorlig personskade eller endda død.

!!! ADVARSEL!!!

> Trampolinen skal inspiceres før brug. Benene skal være låst forsvarligt. Hvis dele bliver beskadiget eller slidt, skal du straks stoppe med at bruge trampolinen, før du udskifter den med godkendte reservedele.

> Hvis du finder tegn på skader på fjedrene, må du ikke bruge trampolinen. Kontakt venligst vores kundeservicerepræsentanter for at bestille/udskifte de originale dele.

> Vær opmærksom på følgende situationer, der kan udgøre potentielle farer:

- Måttens eller rammepolstringens stof er slidt.
- Bøjjet eller ødelagt støttesystem (ramme).

Garanti

Dette produkt er fremstillet under de højeste standarder for kvalitet og udførelse. I et år fra købsdatoen garanterer vi den oprindelige forbruger en gratis udskiftning af eventuelle materiale- eller udførelsesfejl. Fejl eller skader forårsaget af brug af tredjepartstilbehør er ikke dækket af garantien. Denne garanti træder i kraft fra den købsdato, der er vist på købskvitteringen.

Bemærk: Denne garanti gælder kun for den oprindelige forbruger. Produktskader på grund af misbrug af produktet eller forkert installation er IKKE inkluderet.

Manufactured in China for:
Sport Scandinavia A/S
Niels Bohrsvej 2. 9900 Frederikshavn.
DK Tel: +45 70 126 126. E-mail: Info@spsca.dk
www.spsca.dk

Trampoline

User Manual

ASG4475

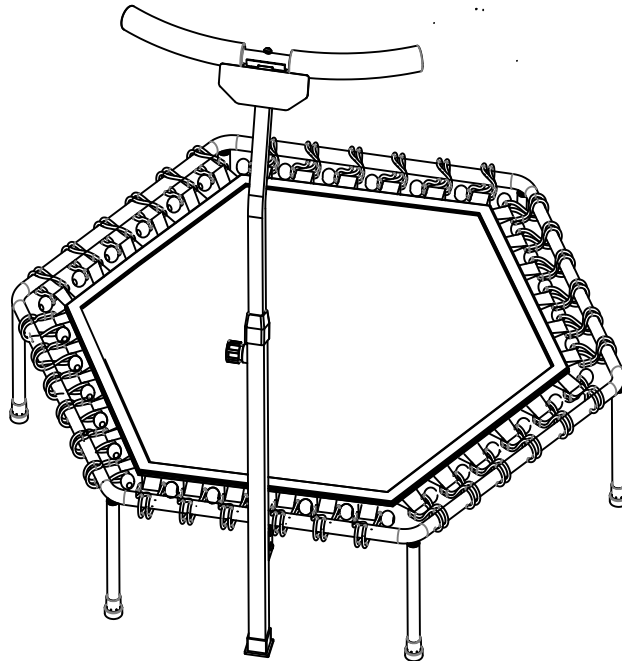

Anything damaged or lost when received it, please contact us for replacements.

Greatly appreciated for sharing your experience online. Wish you a fit life.

CONTENTS

Warnings.....	3-4
Trampoline Parts List.....	5-6
Assembly Instructions.....	7-14
Maintenance.....	15
Warranty.....	16

Note:

Please check the parts against the parts list before assembly. Any parts missing or damaged, and please contact customer service for replacements.

Warnings

! DANGER



NO FLIPS!



ONLY ONE user at one time!
Maximum weight: 100 kg



**DO NOT USE if you
were injured!**



**Remove all hard
or sharp objects
before jumping!**



**DO NOT USE if
pregnant!**

Daily Inspection Before Using

- > Check whether the legs are tightly screwed or cracked.
- > Check whether the bungee cords are loose or damaged.
- > Check whether the mat and stitching are torn.
- > Check whether the frame is twisted or cracked.

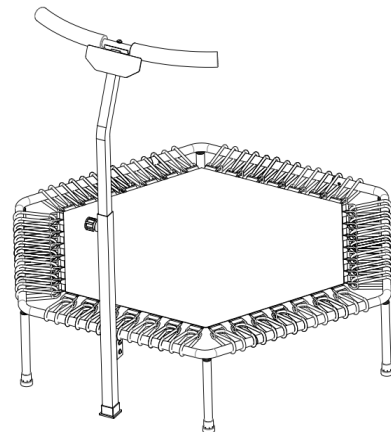

Warnings - User Instructions

Read these instructions and warnings carefully and make sure to always follow them. Follow all assembly and maintenance instructions strictly to ensure the equipment is safe and lasts as long as possible.







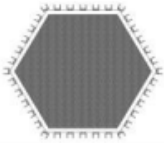

- You must thoroughly read the manual before assembly.
- Consult your physician before beginning exercise; if you have dizziness, nausea, chest pain, back pain, or other abnormal symptoms, STOP your workout and CONSULT A PHYSICIAN IMMEDIATELY before continuing.
- The maximum weight limit (install **36** bungee cords) is **220** lbs. (**100** kgs)
- Do not allow more than one person on the trampoline at any time. Collision hazard.
- Do not allow young children to use unless supervised by an adult.
- It is the responsibility of the owner to ensure that anyone who use the trampoline are fully aware of all warnings and safety instructions.
- This product is intended for use by adults and teens. Please keep an eye on children under 6 years old.
- Do not eat while jumping.

Warnings - Installation Instructions

- Don't allow more than one person on the trampoline. Otherwise it may result in serious injuries.
- Avoid bouncing too high. Stay low until bounce control and always land in the center of the trampoline. Control is most important in bouncing.
- Before using, please make sure all the parts including the legs are tightly set up.
- Adequate overhead clearance is essential. A minimum of (10 ft.) from the ground to the top. Away from wires, ceiling fans, and other possible hazards.
- Place the trampoline away from walls, structures, furniture, and other play areas. Ensure a clear space of 6 ft (1.8 m) on all sides of the trampoline.
- Remove all items under the trampoline.
- Don't use the trampoline in the dark. Artificial lighting may be required.
- Stop bouncing by flexing knees as feet come in contact with the trampoline mat. Learn this skill first.
- Indoor use only.

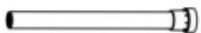
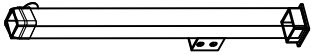
Trampoline Parts List









List 1

Key Number	Part Picture	Description	Quantity
A		T6-Jump Mat	1
B		U-Frame Part	1
C		L-Frame Part	4
D		I-Frame Part	1
E		Leg with Cap	6
F		Handrail Leg	1
G		Handrail Support Rod	1
H		Handrail bar with Foam	1
I		Nameplate part	1

Notes: This trampoline may come with an additional bungee cord for replacement

Trampoline Parts List

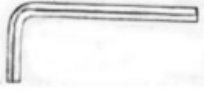
List 2

Key Number	Part Picture	Description	Quantity
1		Bungee	36
2		Adjustable Knob	1
3		D8-Flat Washer	3
4		D6-Flat Washer	2
5		M8X12 Screws	5
6		M6X12 Screws	8
7		Leg Socket Cap (Pre-assembled with #E)	6
8		Hex Key Wrench	1
9		Triangle Tool	1

If parts missing or damaged, please contact us.

Assembly Instructions

One or more strong adults are required to install this trampoline. Always remember to keep your face away from the rails. Failure to do so may lead the rails to spring back then cause harm. Please install the Frame before installing the bungees!

!!!Attention: Please pay attention to the installation order of the frame accessories, read the instructions carefully or watch the installation video before installation.

Step 1 - Install the Frame

1. Lay #B-U-Frame Part on an open floor at the angle shown in the figure.
2. Install four #C-L-Frame Parts in sequence as shown in the figure.
3. Install the #D-I-Frame Part on the frame as shown in the figure to form a completed frame.
4. Use #8-Hex Key Wrench to install #6 M6X12 Screws on the frame to fix the frame.

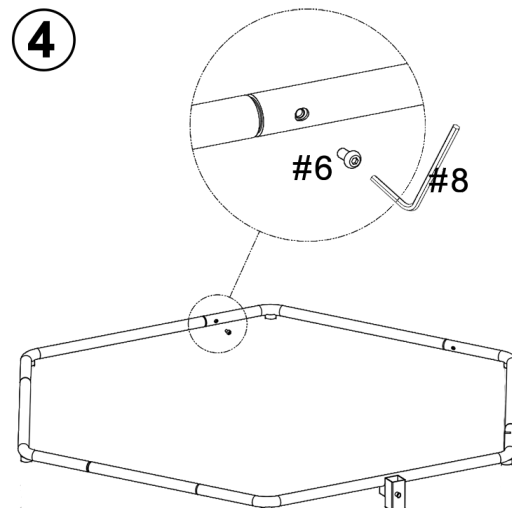
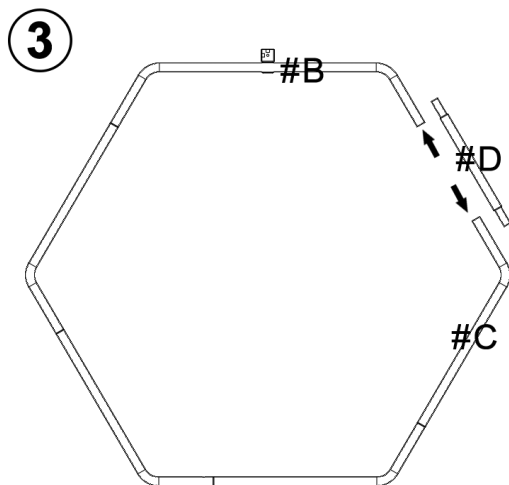
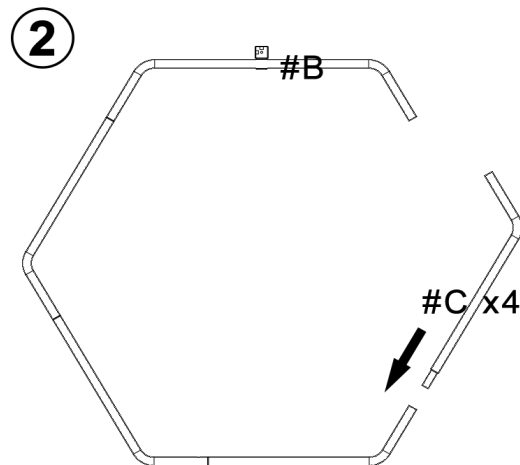
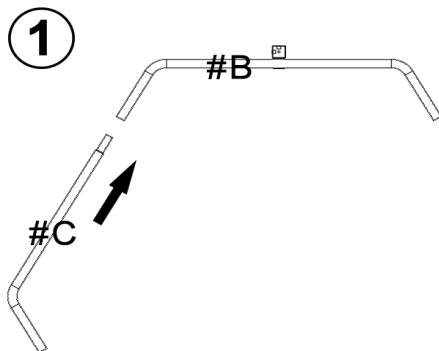

Assembly Instructions

Step 2 - Attach the Bungees

1. Please make sure the metal ring is in the black metal buckle before installing #1-Bungees.
2. Insert the narrow end of #9- Triangle Tool into the bungee cord.
3. Pull back the narrow end of #9- Triangle Tool until the wide end is locked into the black metal buckle.
4. Slide the narrow end of #9- triangle tool towards the mat until the bungee cord snaps into the black metal buckle.

!!!Attention!!!: Make sure the frame is fully fixed before installing the bungees.

①



②



③



④



Assembly Instructions

Step 3 - Install the Jump Mat

The trampoline come with 36 bungees, and you can install bungees according to your need. (It is recommended to install 36 bungees intotal.) If you need more detailed instructions on the bungee cords installation, you can watch the related video at the link.

> Please understand the installation order of the bungees before starting the installation, and it will be easier to install them in order.

1. Put the bungees to the first metal buckle on each side then install the bungees on the 6 leg connect or saccording to the numbers marked in the figure ② to fix the jumping cloth.
2. Install the bungees on the 3th metal buckle on each side in sequence in the picture ③.
3. Then install all the bungees.

!!!Attention!!!: Make sure the frame is fully fixed before installing the bungees.

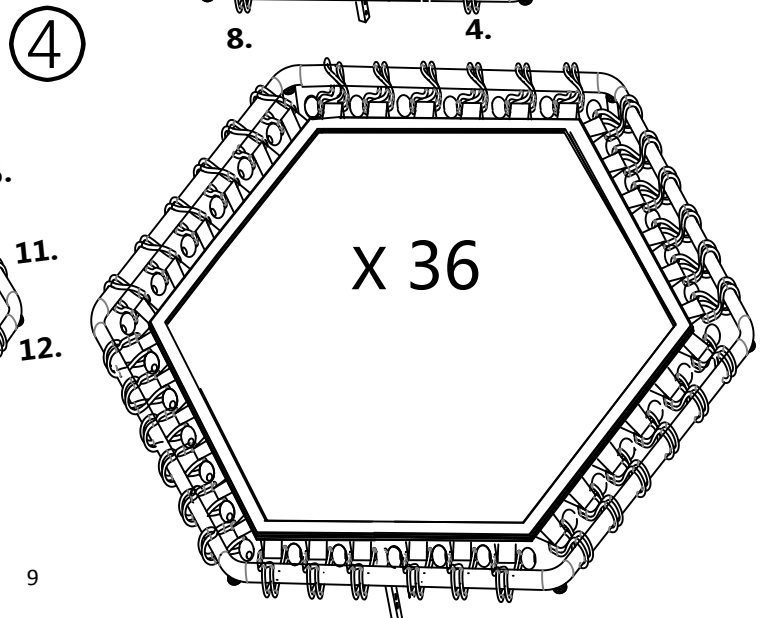
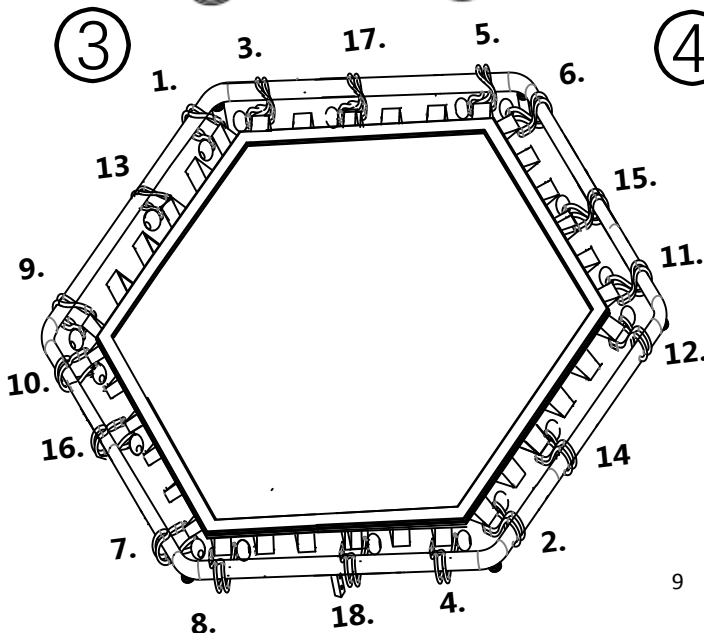
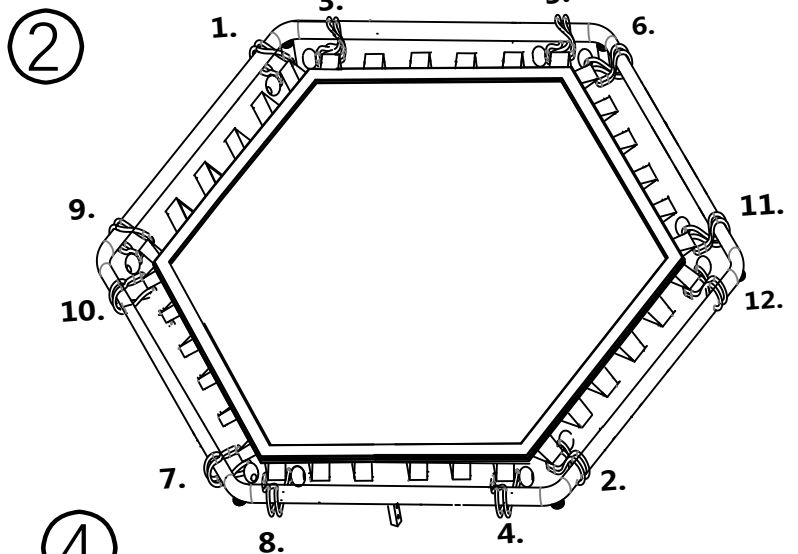
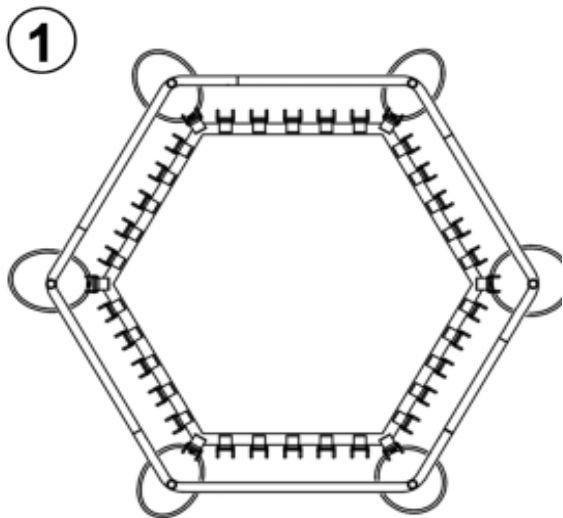

Assembly Instructions

Step 4 - Attach Leg to the Frame

- > Remove all protective end caps from screw threads and discard. Insert #E-Leg onto the leg socket of the trampoline frame and twist clockwise until completely tightened.
- > #11-Washer Pad are used to adjust the level of the legs. If the trampoline doesn't perfectly level, you can put the washers inside the rubber feet to adjust the level.

!!!Attention!!!: All the Legs, and Leg Caps must be screwed tightly. The trampoline must be placed flat on the ground to avoid wobble.

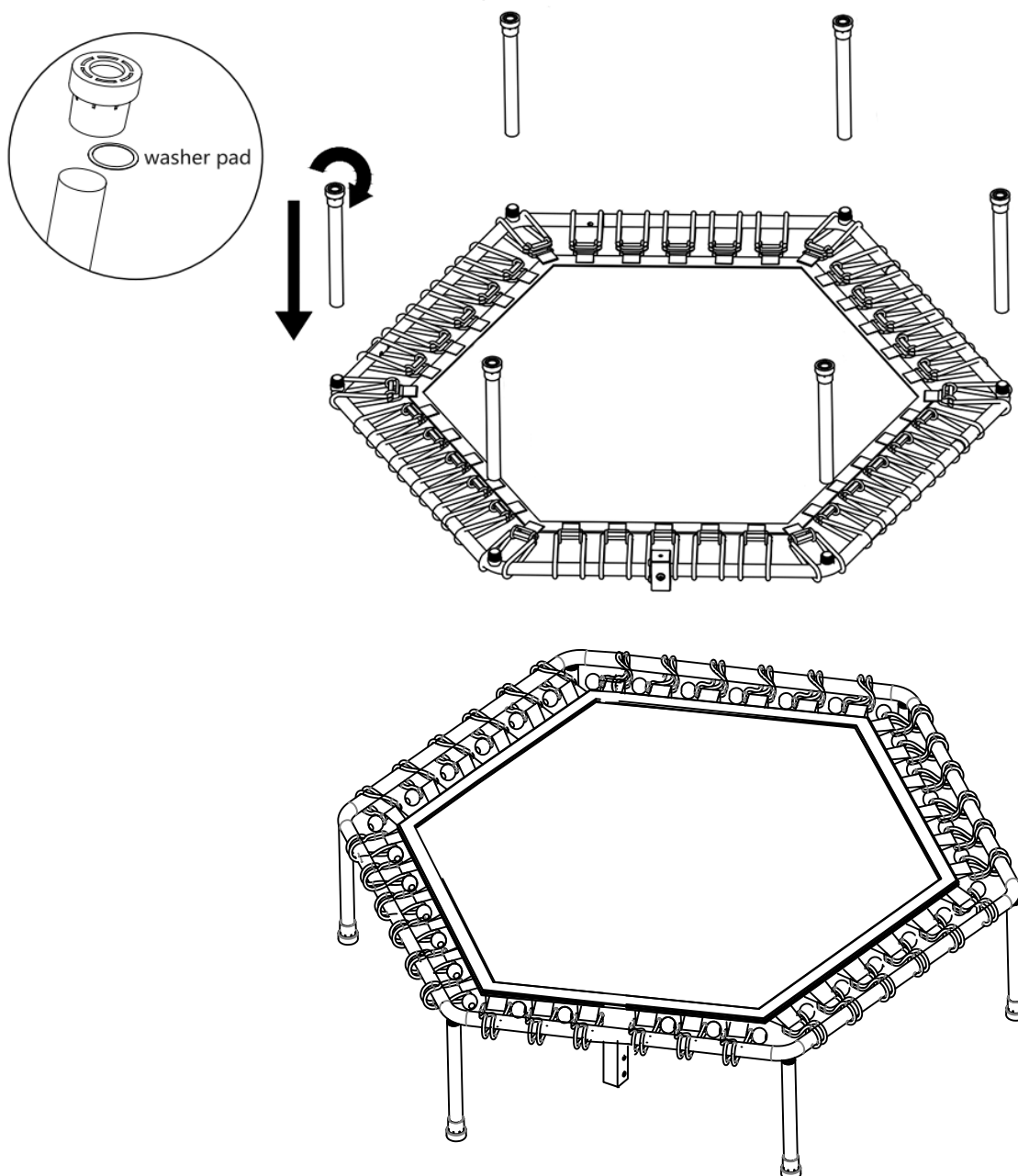

Assembly Instructions

Step 5 - Assemble Handle Bar

- > Put #F- Handrail Leg into the connector, please note that the three holes should be aligned then screw #5- M8X12 Screws and #3- D8-Flat Washer by #8- Hex Key Wrench to secure the handrail leg.

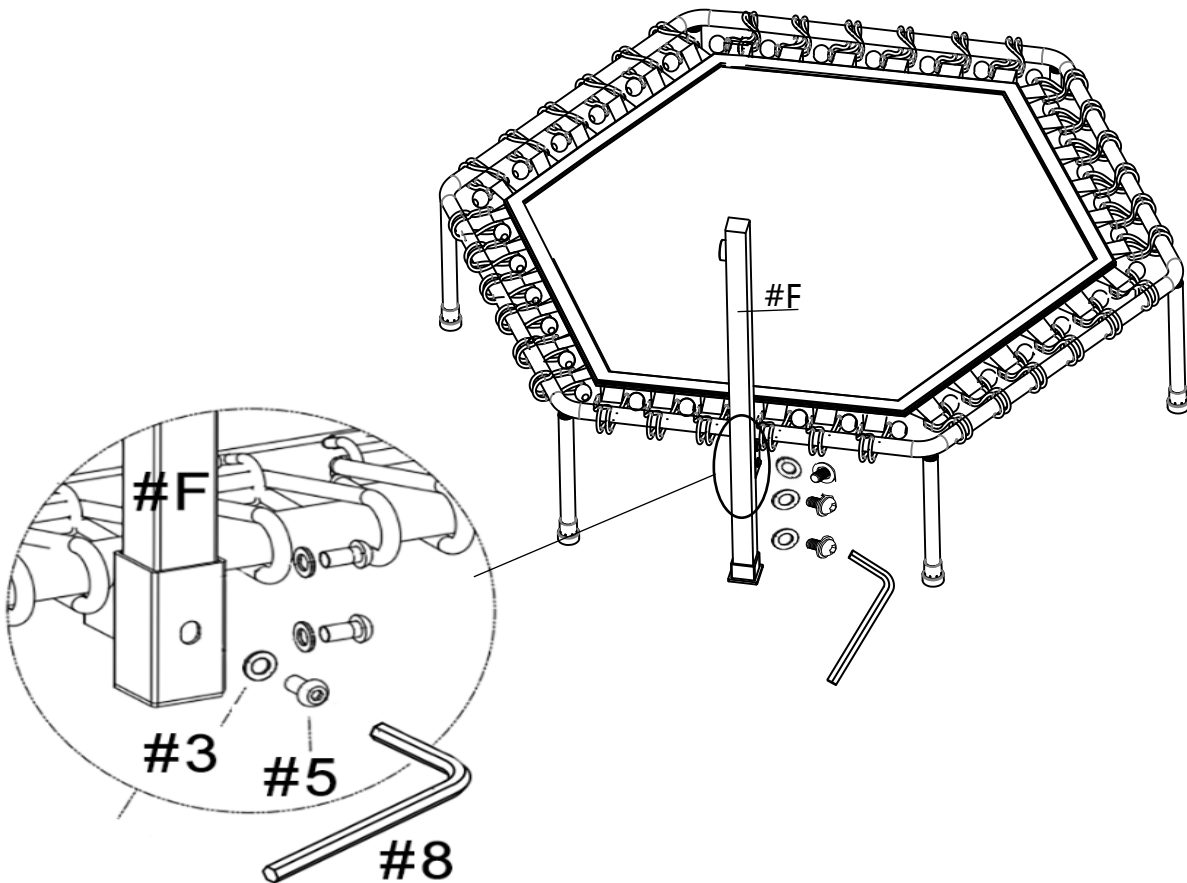

Assembly Instructions

- > Put **#G**- Handrail Support Rod into **#F**- Handrail Leg, adjust the position of the hole according to the height, and then tighten **#2**- Adjustable Knob.

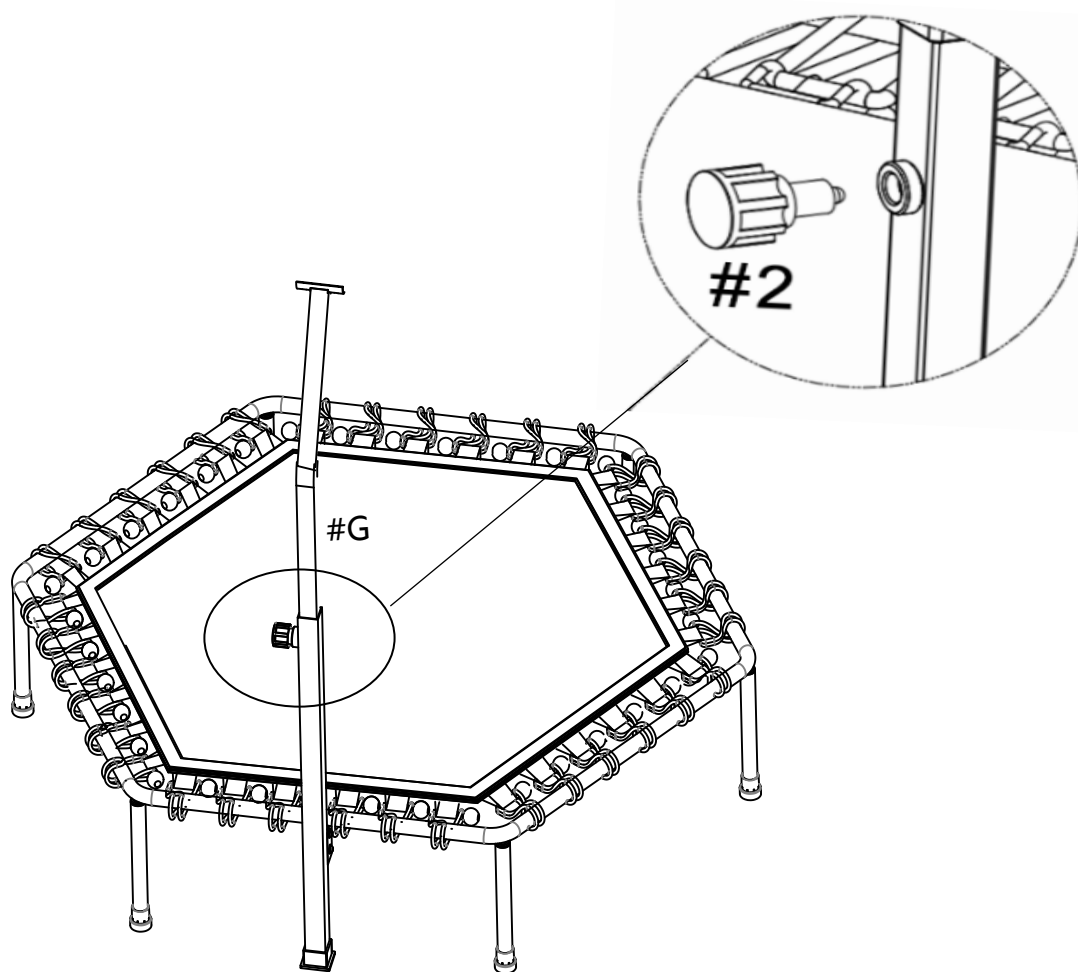

Assembly Instructions

- > Attach **#H**- Handrail Bar with Foam to **#G**- Handrail Support Rod, then assemble **#5**- M8X12 Screws by **#8**- Hex Key Wrench.
- > Attach **#I**- Nameplate Part with Handle Bar, then assemble **#6**- M6X12 Screws and **#4**- D6-Flat Washer by **#8**- Hex Key Wrench.

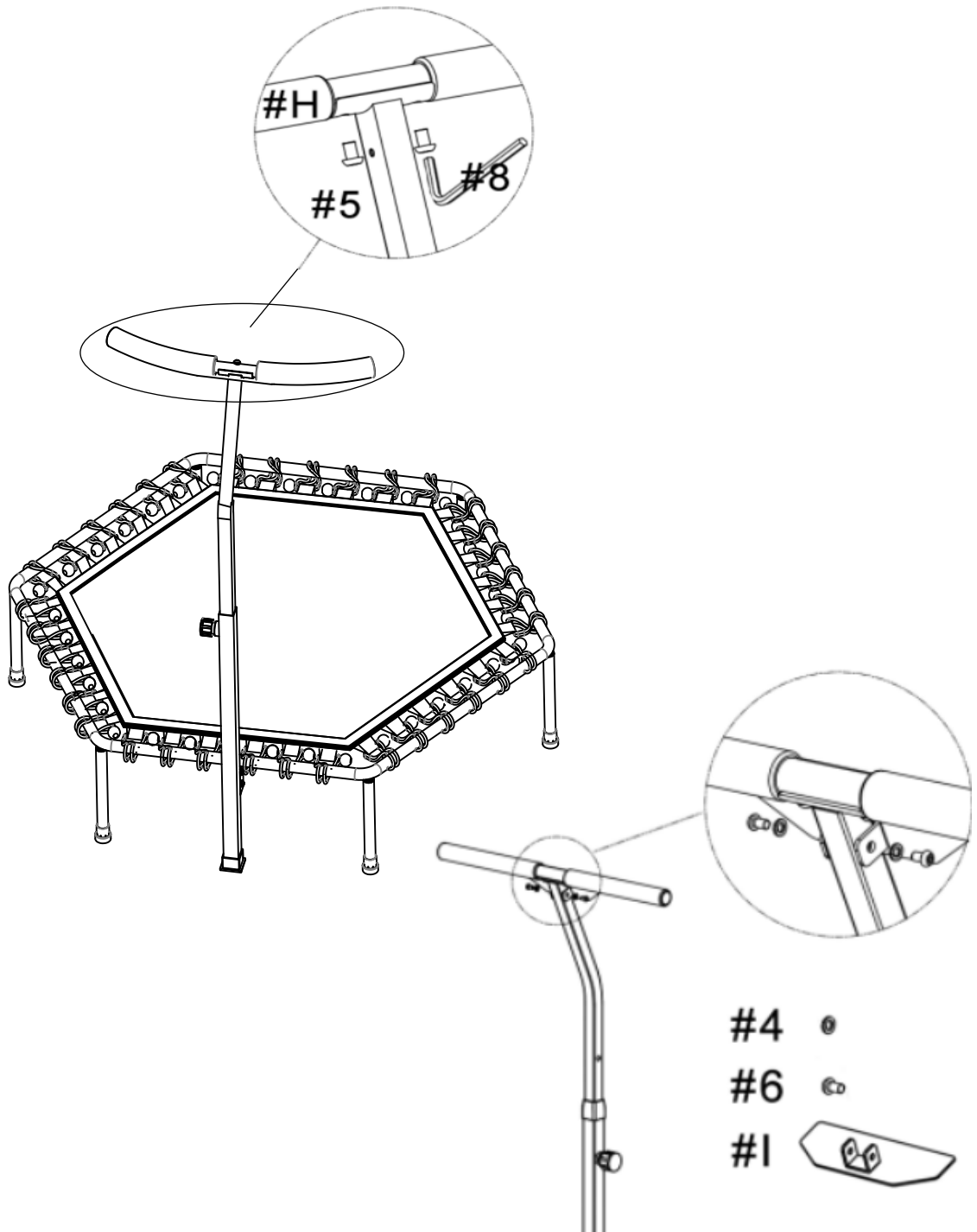

Assembly Instructions

> Once the trampoline is fully installed, you can enjoy the fun of trampoline.

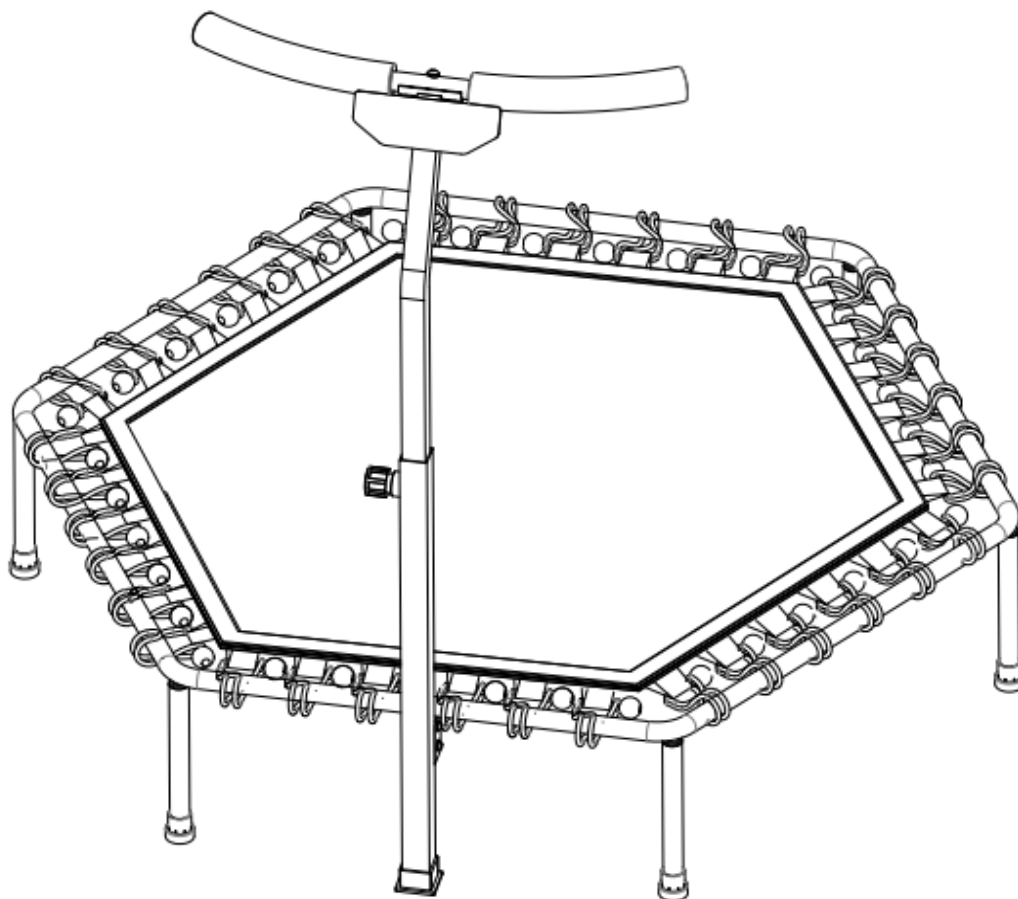

Maintenance



Failure to comply with these instructions or operate properly may lead to serious injury or even death.

!!! WARNING!!!

- > The trampoline must be inspected prior to use. The legs should be locked securely. If any parts become damaged or worn, please stop using the trampoline immediately before replacing it with authorized parts.
- > If you find any signs of damage to springs, do not use the trampoline. Please contact our customer service representatives to order/replace the original parts.
- > Please pay attention to the following situations that may represent potential hazards:
 - The fabric of the mat or frame padding is aging.
 - Bent or broken support system (frame).

Warranty

This product has been manufactured under the highest standards of quality and workmanship. For **one year** from the date of purchase, any material or workmanship defects, we guarantee to the original consumer a free replacement. Defects or damaged caused by the use of 3rd accessories are not covered by the warranty. This warranty shall be effective from the date of purchase shown in the purchase receipt.

Notice: This warranty is valid for the original consumer only. Product damage due to product abuse, or improper installation are NOT included.

Manufactured in China for:
Sport Scandinavia A/S
Niels Bohrsvej 2. 9900 Frederikshavn.
DK Tel: +45 70 126 126. E-mail: Info@spsca.dk
www.spsca.dk