

# OTALS8X8

## Aufbauanleitung

DE - Bevor Sie beginnen:

- Es ist empfehlenswert sich etwas Zeit zu nehmen, um die Aufbauanleitung zu lesen, bevor mit dem Aufbau begonnen wird.
- Der Aufbau sollte in der vorgegebenen Reihenfolge erfolgen.
- Die Aufbauanleitung dient lediglich als Richtschnur für den Aufbau. Nicht alle Schritte sind im Detail vorgegeben.
- Bitte prüfen Sie alle Teile auf Vollständigkeit und Zustand vor dem Aufbau. Der Aufbau sollte durch mindestens 2 Personen erfolgen.
- Bei starkem Wind sollte der Aufbau nicht erfolgen.
- Bohren Sie die Teile vor, wo es angezeigt wird.
- Wir empfehlen, das Gerätehaus erst nach weitgehendem Aufbau vor Anbringung der Deckleisten mit Farbe oder Holzlasur zu behandeln, da sich die Elemente bei einer einseitigen Behandlung verziehen können, wodurch der Aufbau erschwert werden könnte.

## Instructions d'assemblage

FR - Avant de commencer:

- Avant de commencer le processus d'assemblage, veuillez s'il vous plaît vous familiariser parfaitement avec les instructions.
- La maison doit être assemblée suivant la séquence indiquée dans les instructions.
- Les instructions s'entendent comme lignes directrices, toutes les étapes ne sont pas décrites en détails.
- Avant de commencer l'assemblage, vérifier tous les éléments.
- Deux personnes sont nécessaires au minimum pour l'assemblage.
- Ne pas tenter d'assembler la maison dans des conditions de vents forts.
- Percer les trous dans les éléments suivant les marques.

## Montage-instructie

NL - Alvorens te beginnen:

- Voordat u begint met de montage raden wij u aan de handleiding grondig door te lezen.
- Bij de montage van het huis dient u de volgorde zoals deze in de handleiding is
- aangegeven te volgen.
- De handleiding is bedoeld als richtsnoer, niet alle stappen zijn in detail uitgewerkt.
- Vóór de montage dienen alle details gecontroleerd te worden.
- De montage van het huis dient door tenminste twee personen uitgevoerd te worden.
- Het huis nooit in harde wind opbouwen.
- Gaten in onderdelen boren, waar dit staat aangegeven.

## Pokyny k montáži

CZ - Než začnete:

- Než začnete s montáží, seznamte se důkladně s těmito pokyny.
- Domek musí být sestaven v pořadí uvedeném v pokynech.
- Pokyny slouží pouze jako vodítko, ne všechny kroky jsou zde popsány dopodrobna.
- Než začnete s montáží, zkontrolujte všechny díly.
- K montáži jsou zapotřebí minimálně dvě osoby.
- Nepokoušejte se smontovat domek za silného větru.
- Vyvrtejte do dílů otvory podle značek.

## Pokyny pre montáž

SK - Predtým, než začnete:

- Predtým, než začnete montovať, sa, prosím, dôkladne oboznámte s týmito pokynmi.
- Dom je potrebné zmontovať podľa poradia uvedeného v pokynoch.
- Tieto pokyny poskytujú návod, nepopisujú však detailne všetky kroky.
- Predtým, než začnete montovať, skontrolujte všetky časti.
- Pri montáži sú potrební najmenej dvaja ľudia.
- Nepokúšajte sa montovať dom pri silnom vetre.
- Otvory v jednotlivých častiach vyvrtajte podľa označenia.

V.3

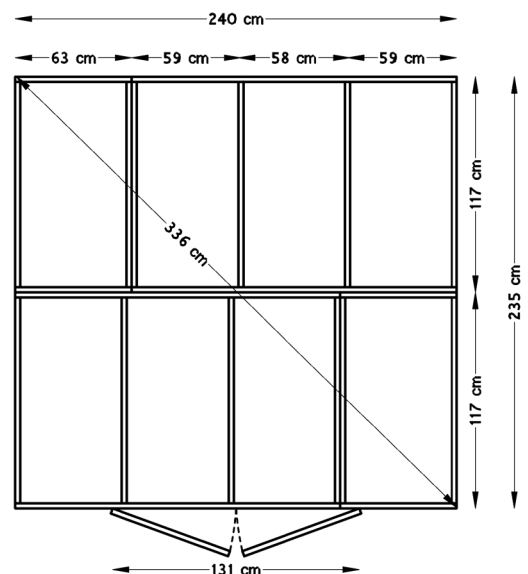
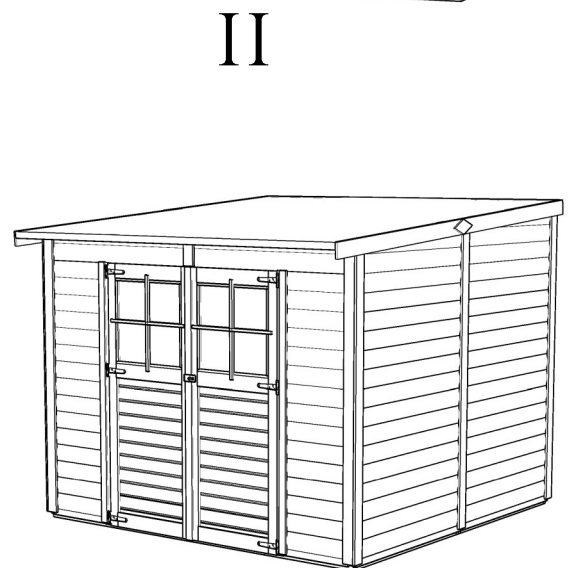
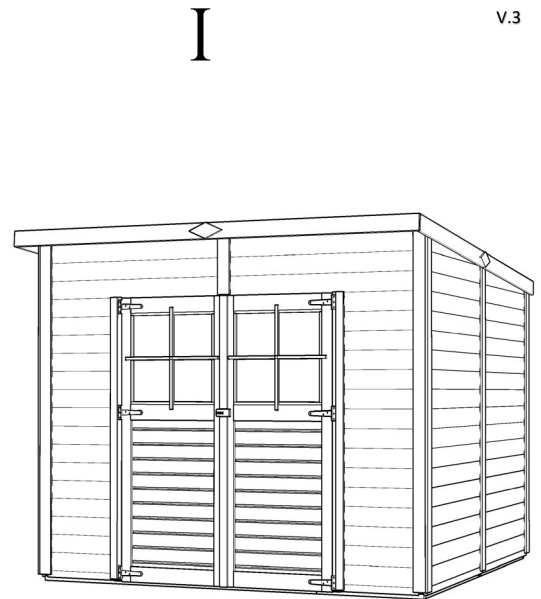

# OTALS8X8

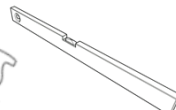
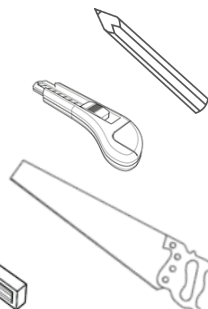
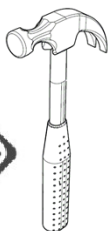
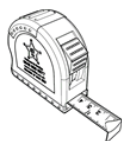

Ø 4 mm  
Ø 10 mm

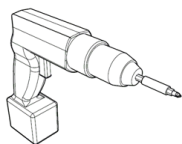

Pos.	Details in cm	Pcs.
1.	28 x 117	1
2.	36 x 117	1
3.	63 x 117	2
4.	36 x 117	1
5.	36 x 117	1
6.	52 x 117	1
7.	65 x 169	2

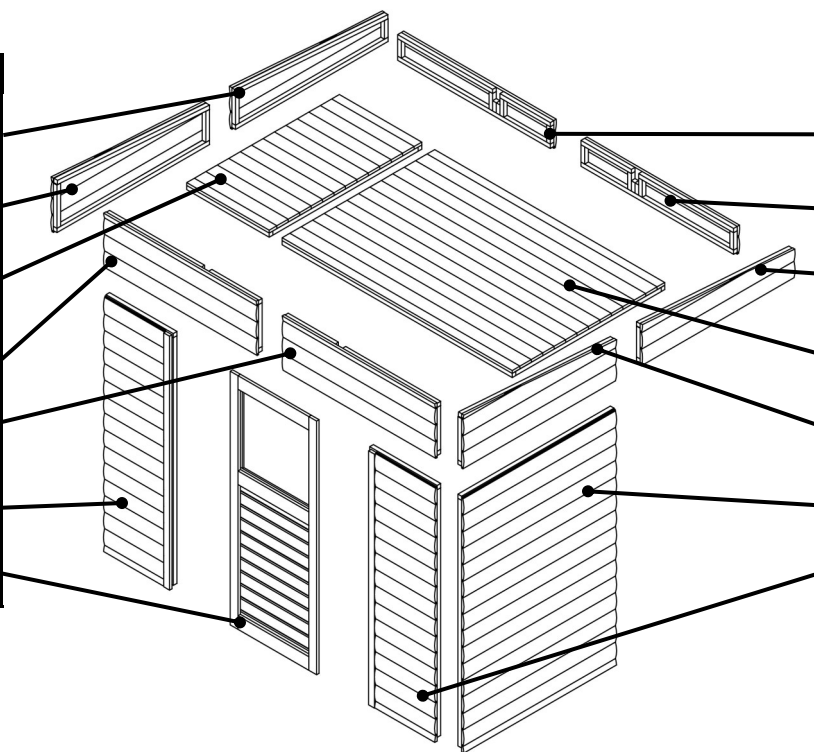

Pos.	Details in cm	Pcs.
8.	18 x 117	1
9.	18 x 117	1
10.	28 x 117	1
11.	117 x 170	2
12.	36 x 117	1
13.	117 x 170	6
14.	52 x 117	1

# OTALS8X8

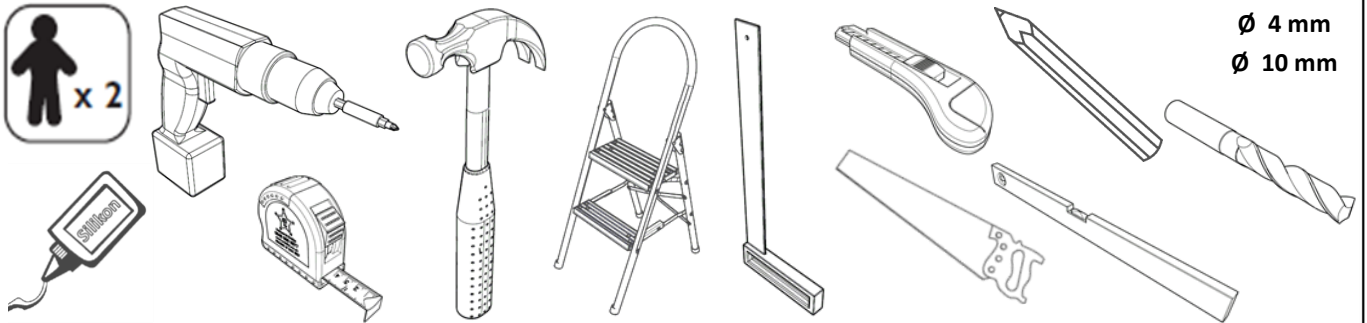

Ø 4 mm  
Ø 10 mm

Pos.	Details in cm	Pcs.
13a.	1,9 x 4,5 x 36	2
14a.	1,9 x 4,5 x 18	2
15.	1,2 x 7 x 36	7
16.	1,2 x 7 x 18	5
17.	1,2 x 7 x 168	11
18.	1,9 x 4,5 x 168	4
19.	1,2 x 4,2 x 168	3
20.	1,5 x 1,5 x 53	8
21.	1,5 x 1,5 x 60	4
22.	54 x 54	2
23	2,8 x 2,8 x 131	1

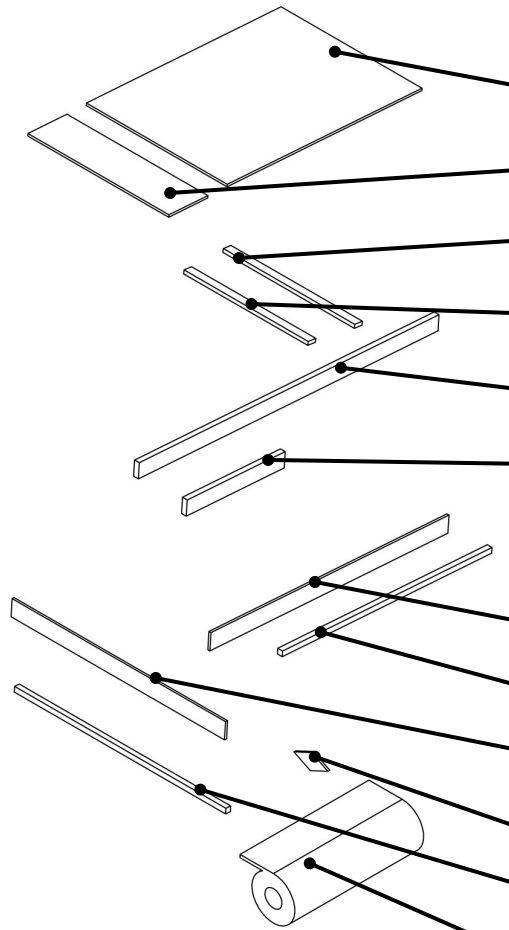
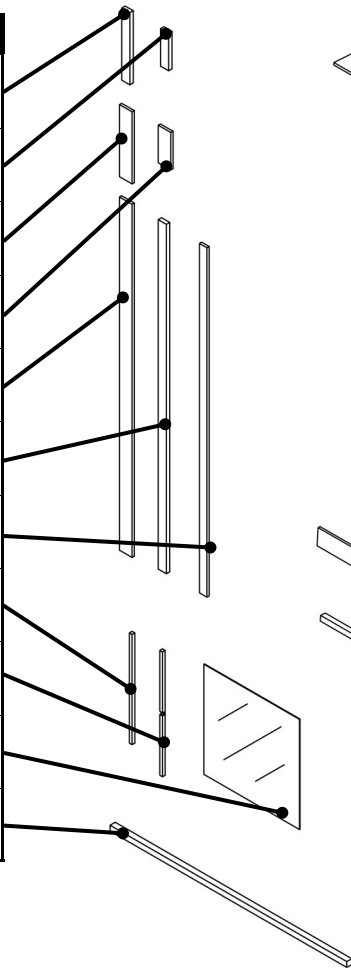

Pos.	Details in cm	Pcs.
24.	83 x 1150	6
25.	23 x 83	3
26.	1,9 x 45 x 77	2
27.	1,9 x 45 x 73	4
28.	2,8 x 80 x 177	4
29.	2,8 x 80 x 58	4
31.	1,2 x 9 x 126	4
32.	2,8 x 2,8 x 123	4
33.	1,2 x 9 x 125	2
34.	1,2 x 9 x 20	3
35.	2,8 x 2,8 x 124	4
36.	100 x 260	3

**37.**  
Ø3,0x20mm  
7 Pcs



**38.**  
Ø4x25mm  
36 Pcs



**39.**  
Ø3,5x30mm  
44 Pcs



**40.**  
2 Pcs



**41.**  
1 Pcs

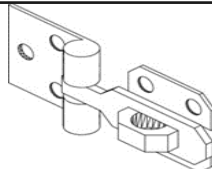

**42.**  
6 Pcs

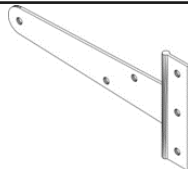

**43.**  
Ø4,5x50mm  
131 Pcs

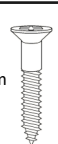

**44.**  
Ø3,5x35mm  
199 Pcs



**45.**  
Ø3x25mm  
36 Pcs

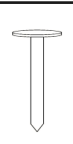

**46.**  
Ø3x14mm  
170 Pcs

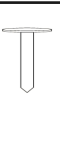

# Fundamenthinweis / Foundation TIP

## \* Nicht im Lieferumfang enthalten / Not included!

\* Unterlagspad /  
\* Patio Pads

Min. 16,9 lfm/rm

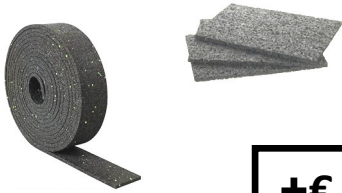

\* Imprägniert Kantholz /  
\* Impregnated beam

40\*60\*2404 mm  
7 Stck/Pcs

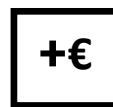

\* Schraube /  
\* Screw

4,5\*80 mm  
42 Stck/Pcs



## Fundamentplan / Foundation Plan

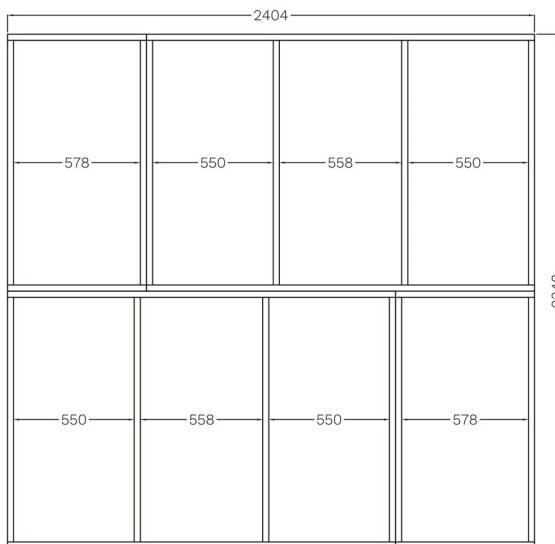

Imprägniertes Kantholz /  
Impregnated beam

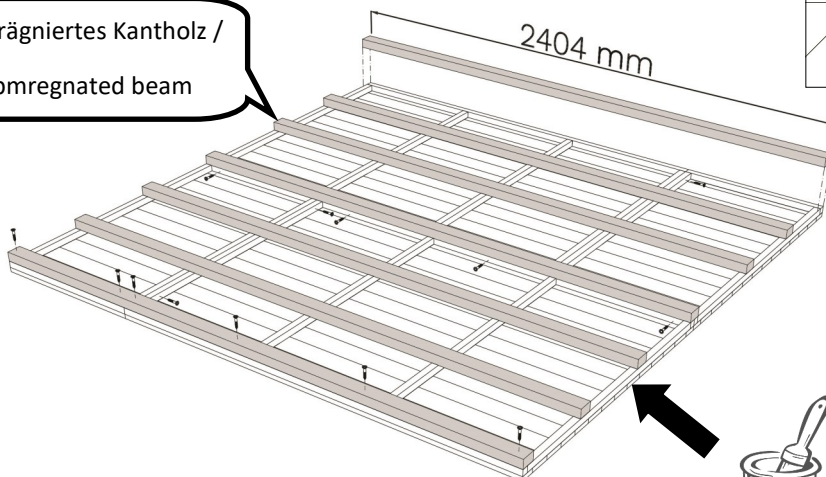

Holzschutzmittel / Wood preservative

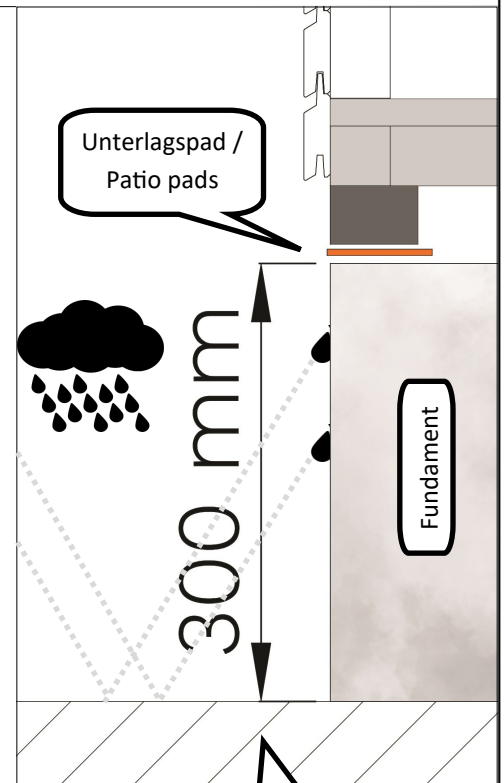

Der Grund /  
Ground

### Bitte beachten!

Lass Dein Bauvorhaben vorab bei Deiner zuständigen Gemeinde prüfen, denn die Bauordnungen sowie die Bebauungspläne müssen eingehalten werden.

### Please note!

Have your construction project checked in advance at your responsible municipality, because the building regulations and the development plans must be observed.

# OTALS8X8

1.

Holzschutz-  
mittel / Wood  
preservative



4 mm



50 mm x 14 St

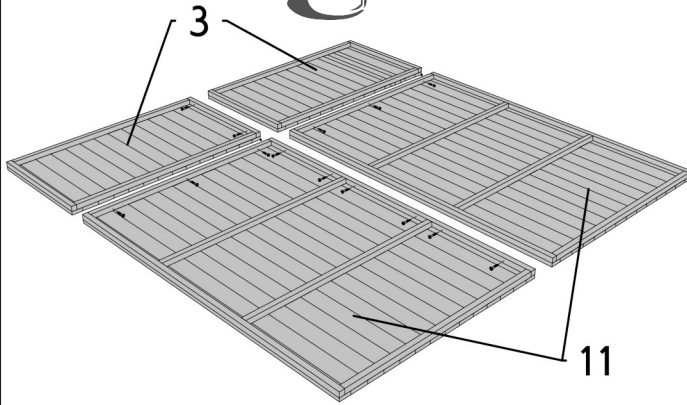

2.

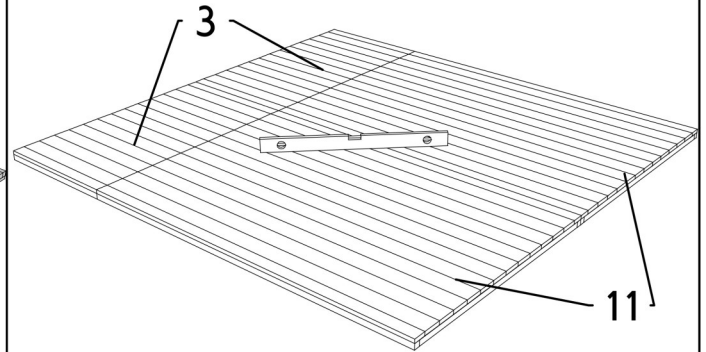

3.

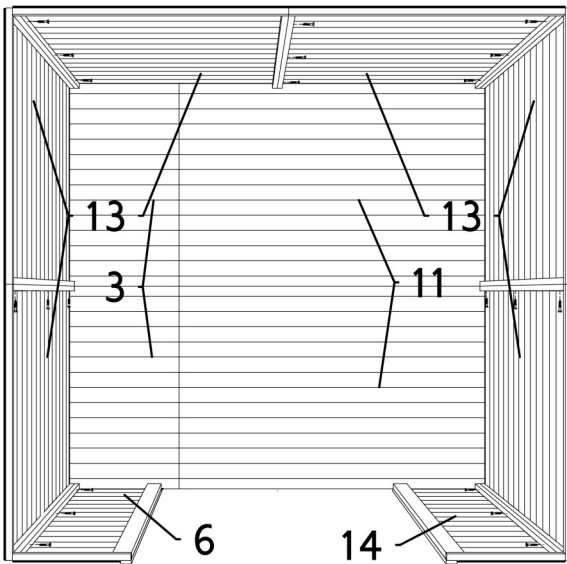

4.

4 mm



50 mm x 3 St

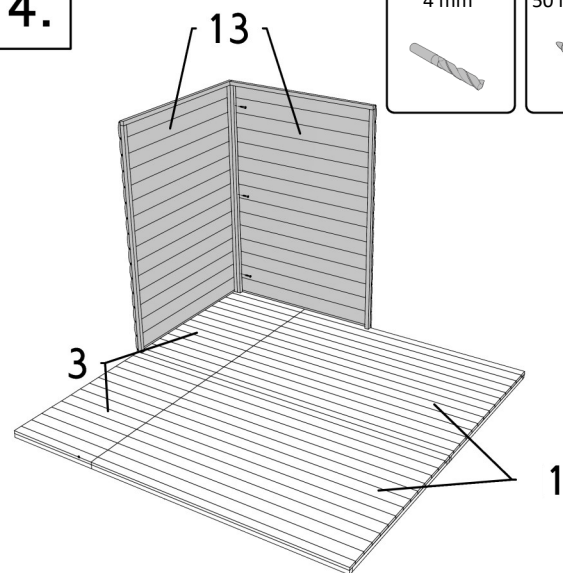

5.

4 mm



50 mm x 6 St

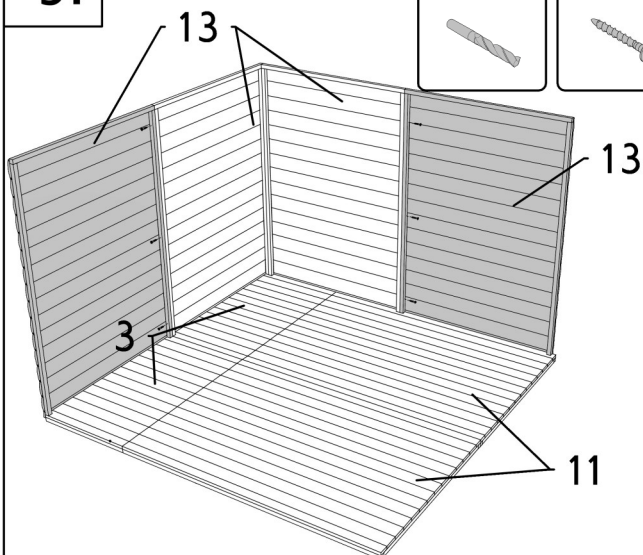

6.

4 mm



50 mm x 6 St

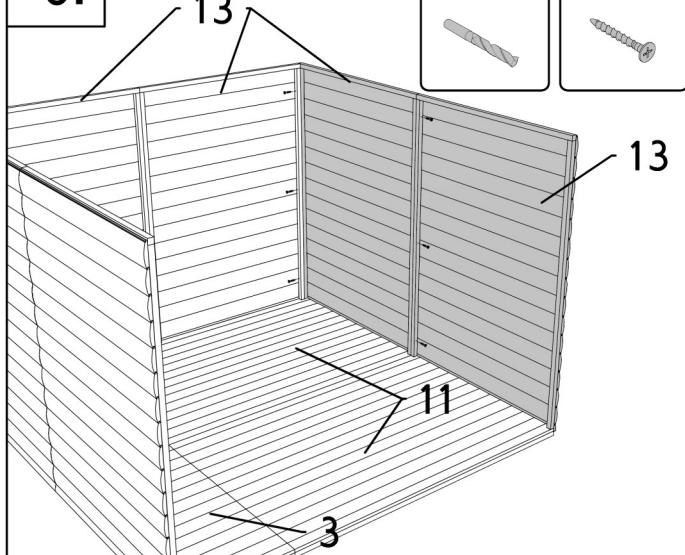

# OTALS8X8

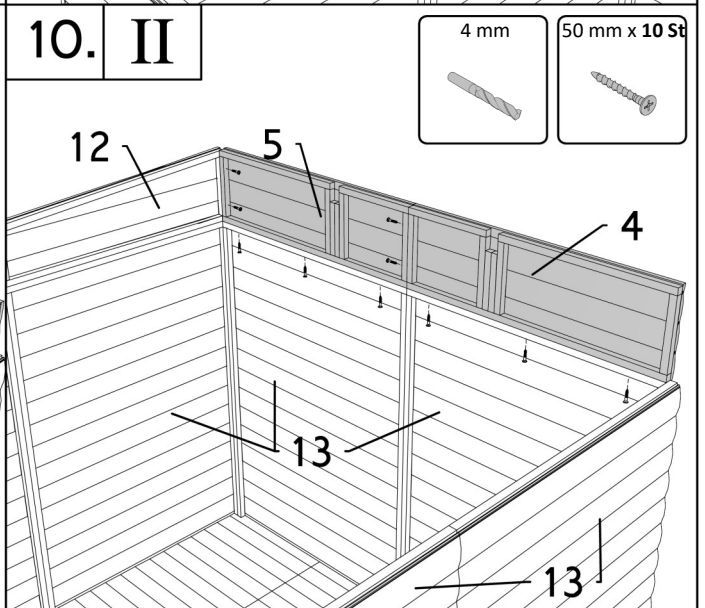
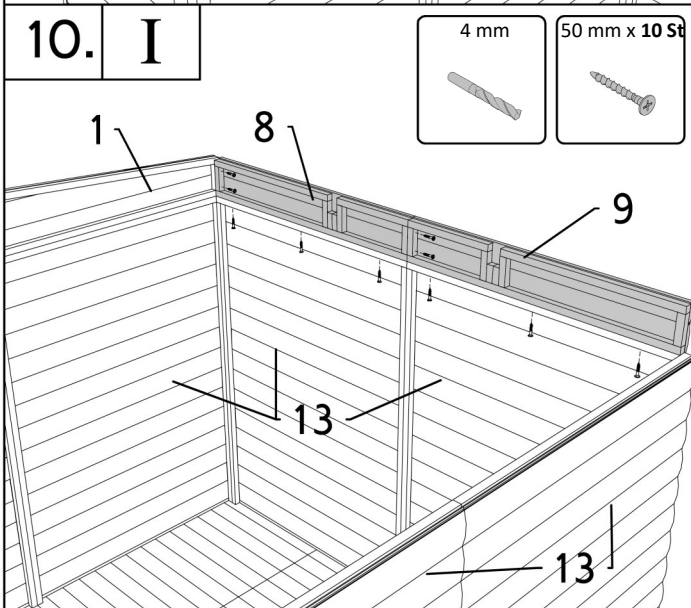
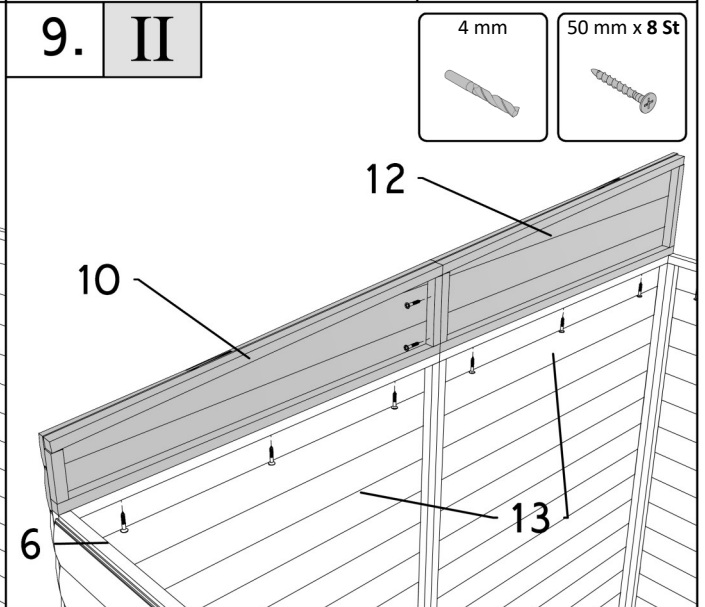
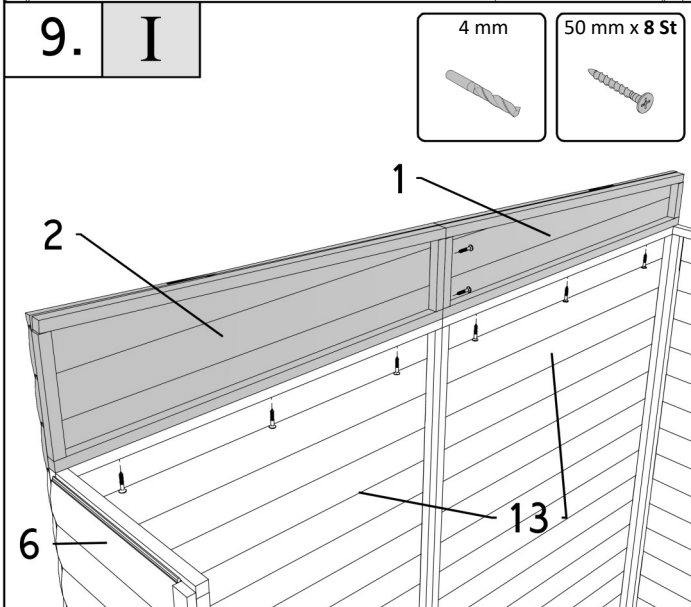
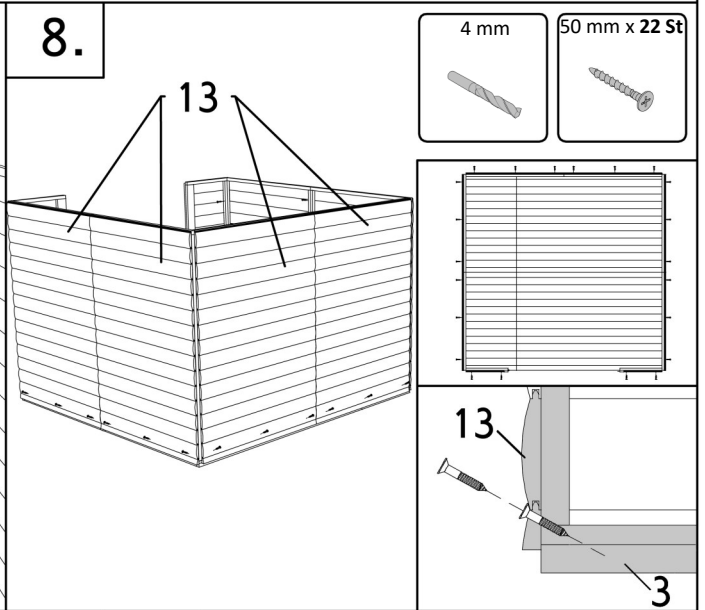
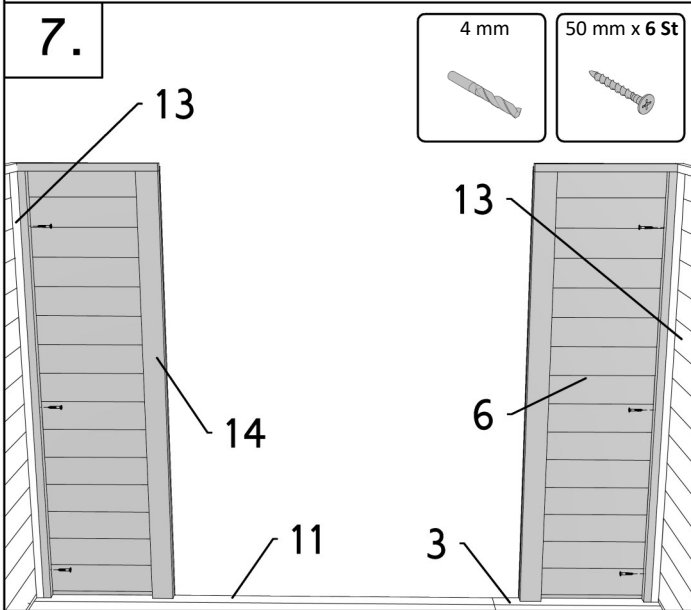

# OTALS8X8

11. I

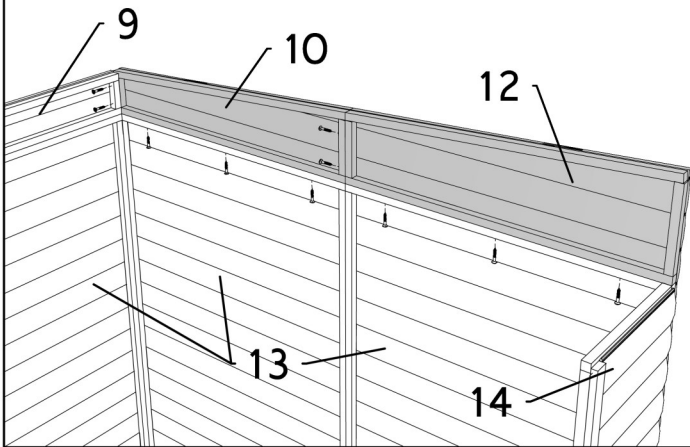
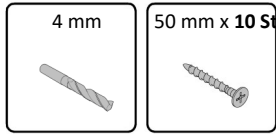

11. II

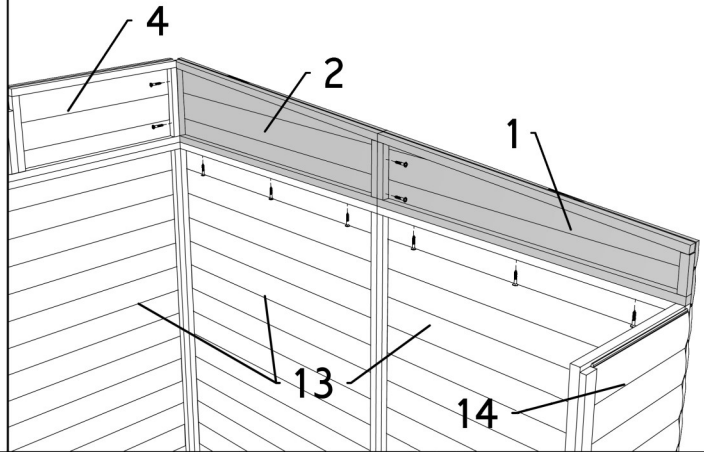
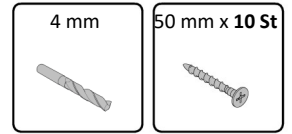

12. I

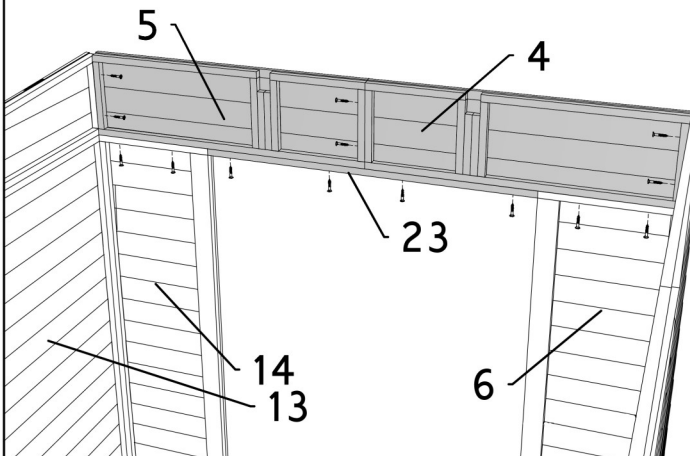
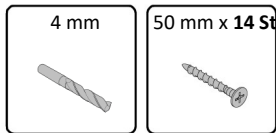

12. II

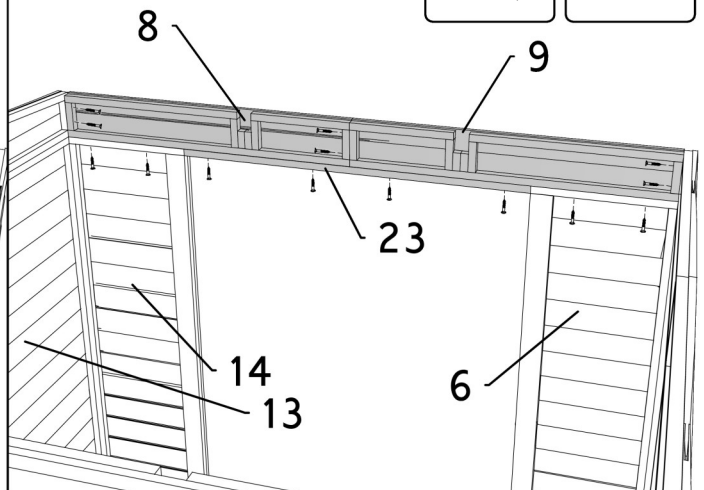
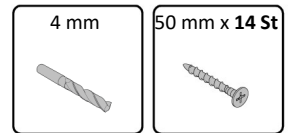

13. x4

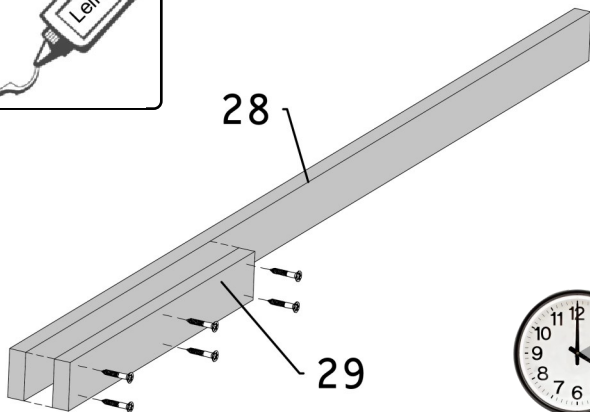
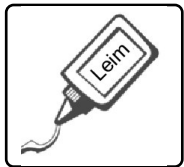
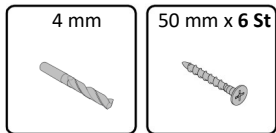

1 Hour/Stunde

14. x2

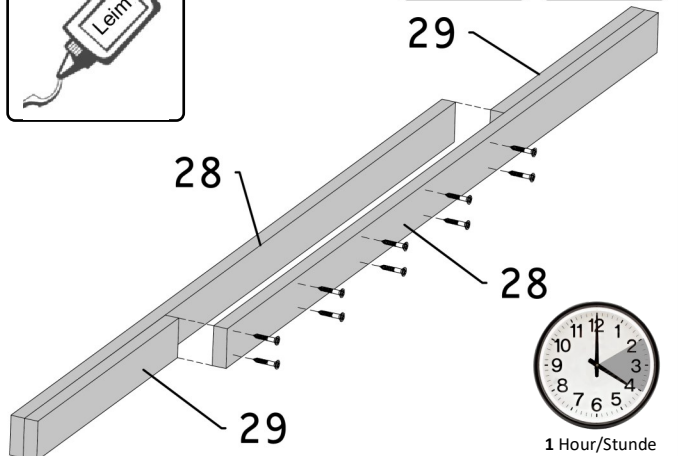
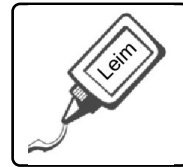
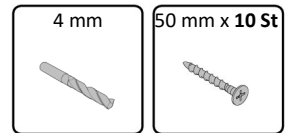

1 Hour/Stunde

# OTALS8X8

15. I

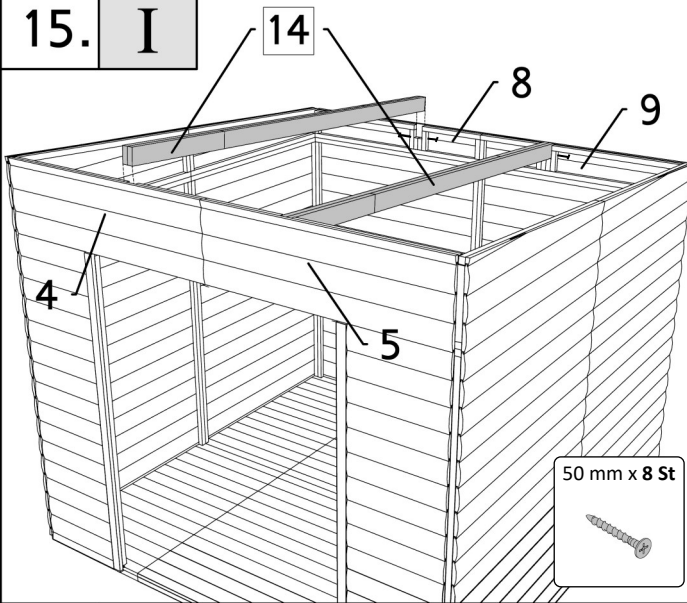

15. II

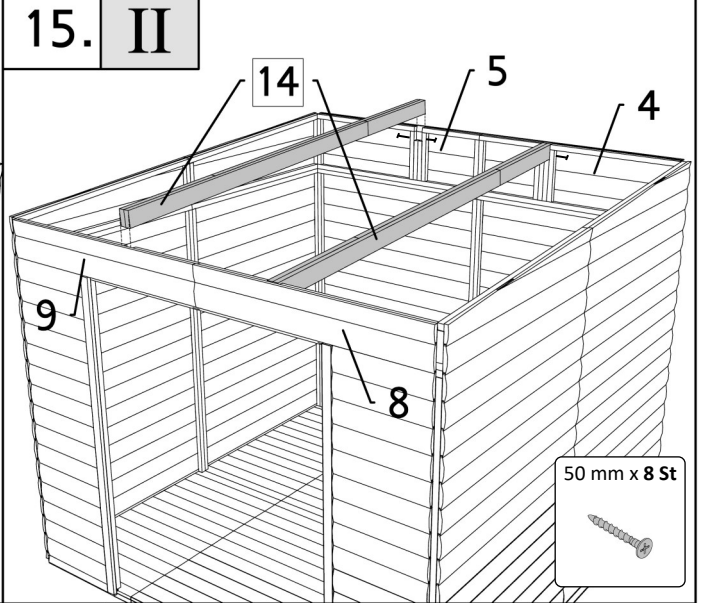

17.

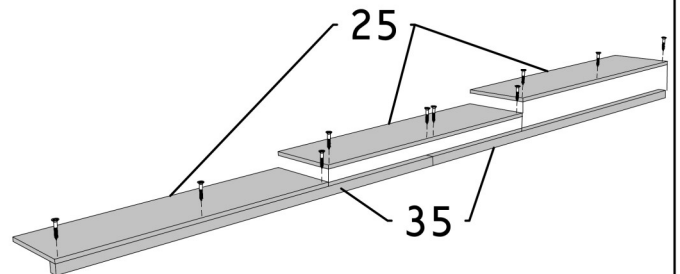
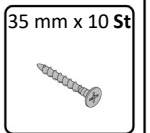

18. I

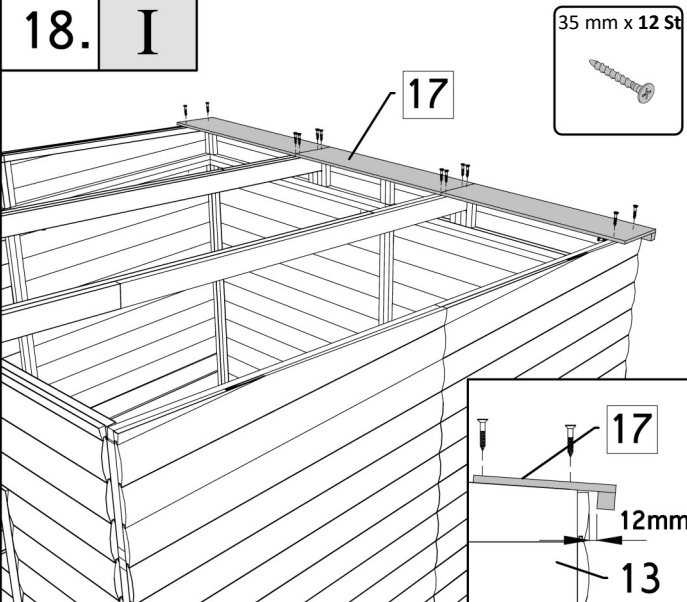

18. II

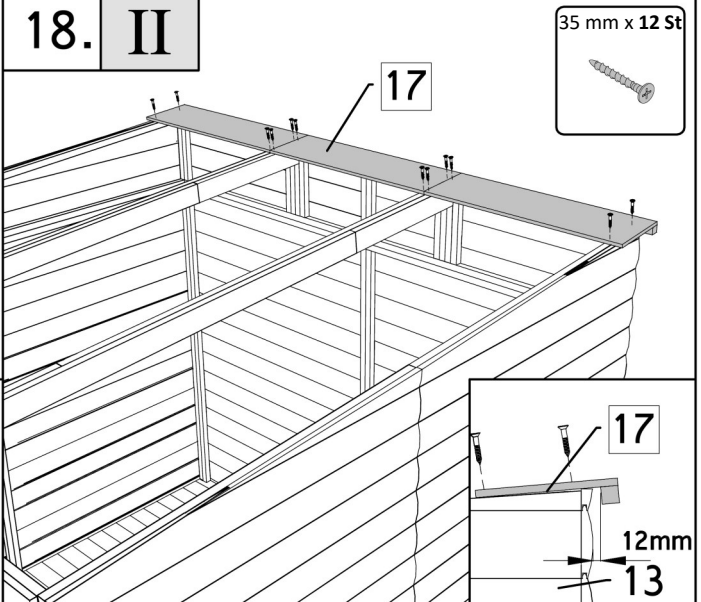



# OTALS8x8

19.

35 mm x 8 St

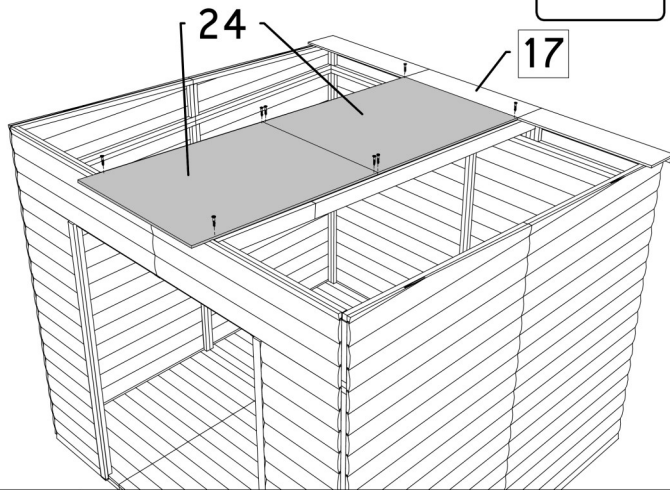

20.

35 mm x 16 St

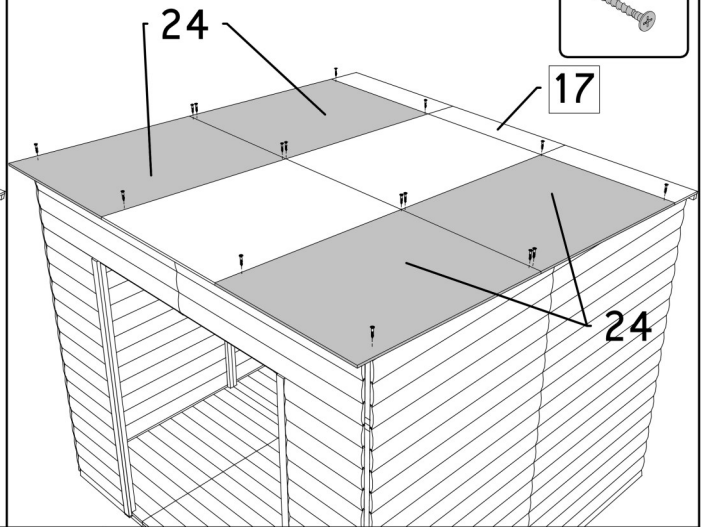

21.

35 mm x 18 St

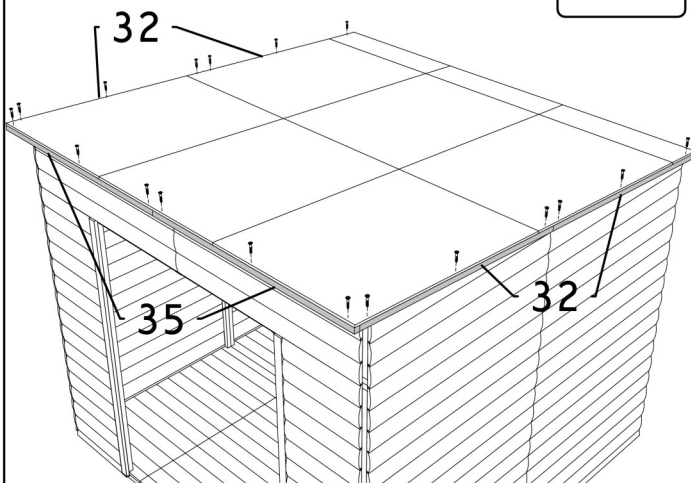

22.

25 mm x 36 St

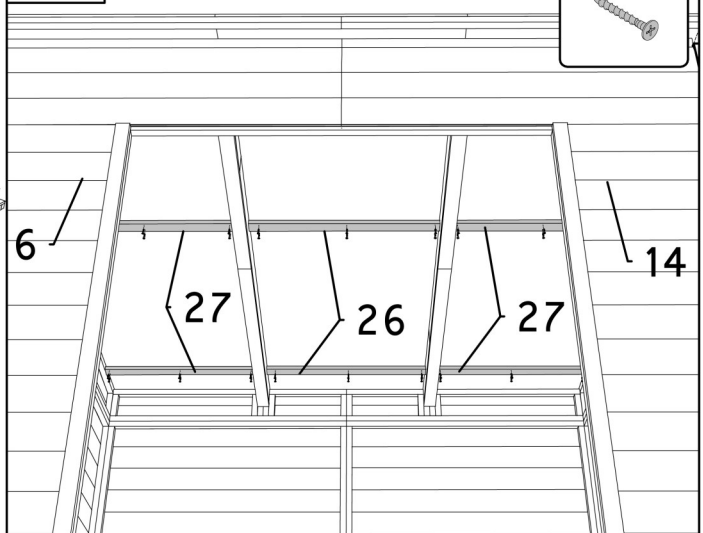

23. I

35 mm x 20 St

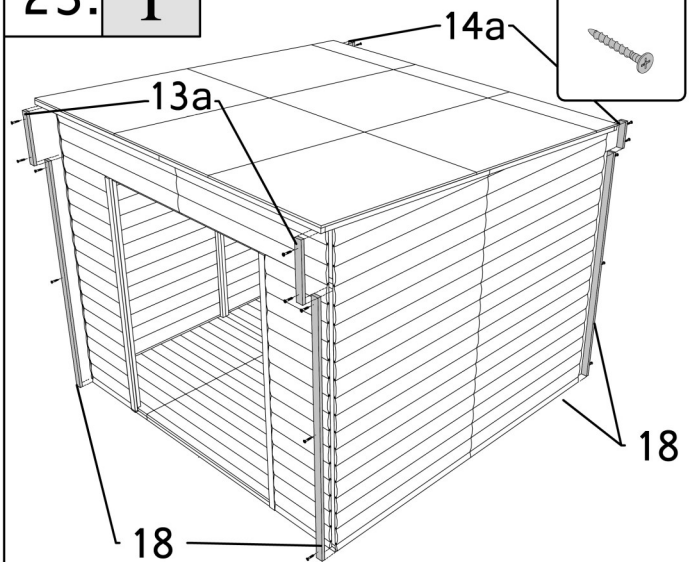

23. II

35 mm x 20 St

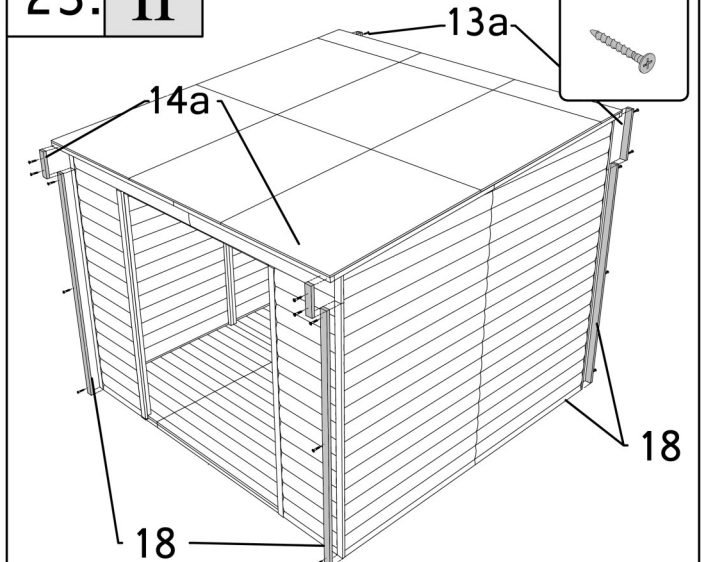

# OTALS8X8

24. I

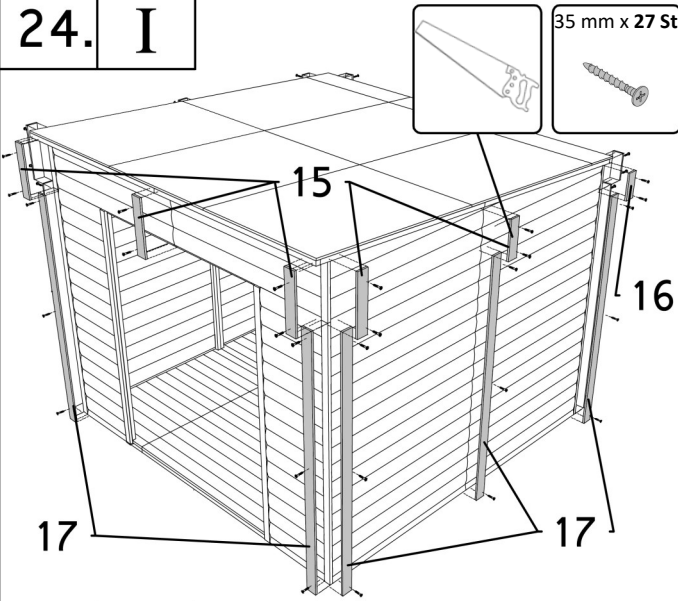

24. II

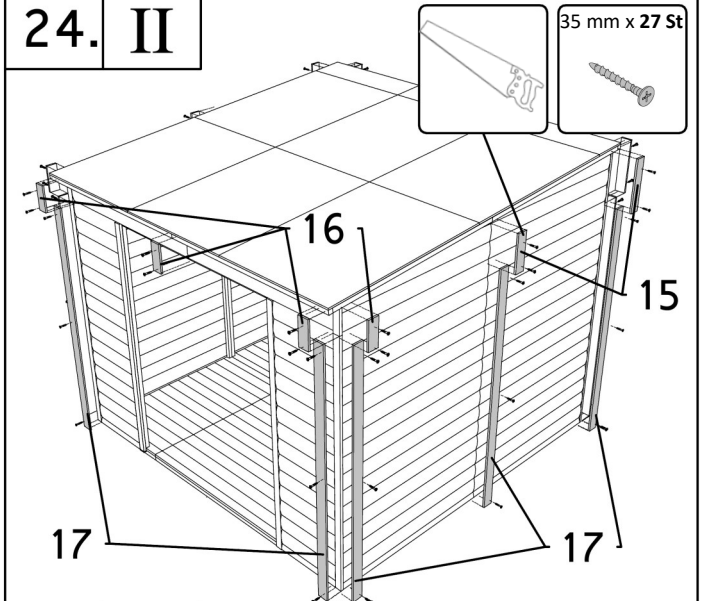

25. I

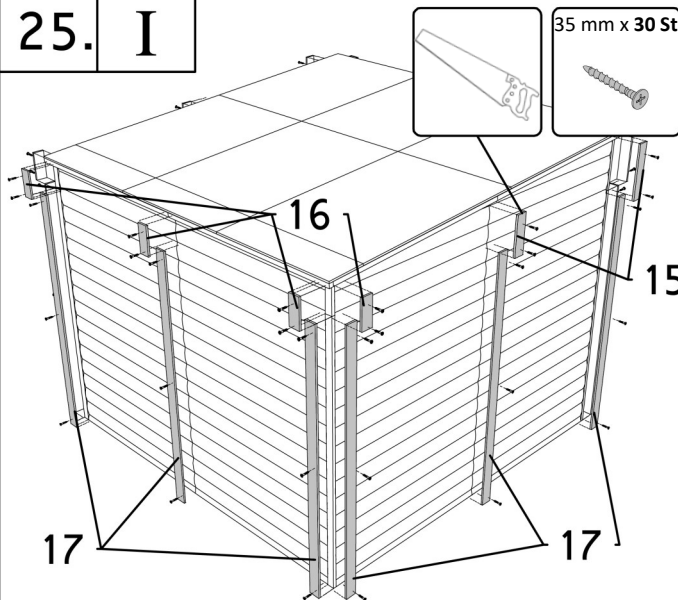

25. II

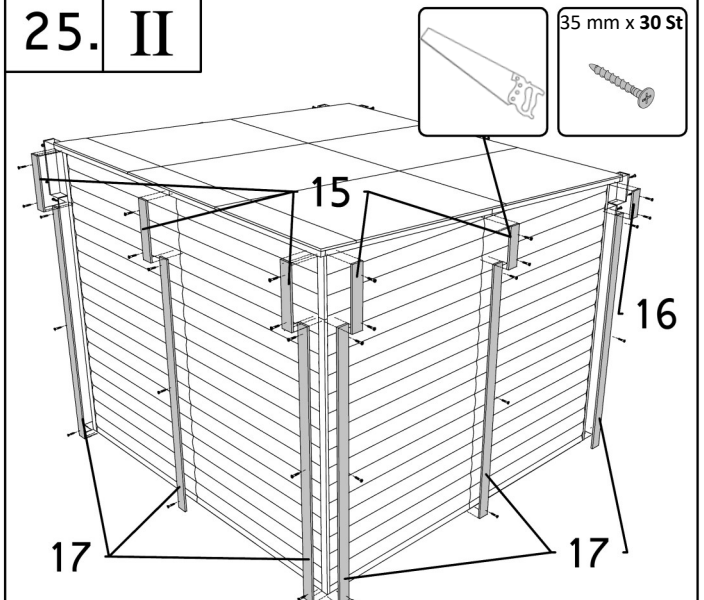

26.

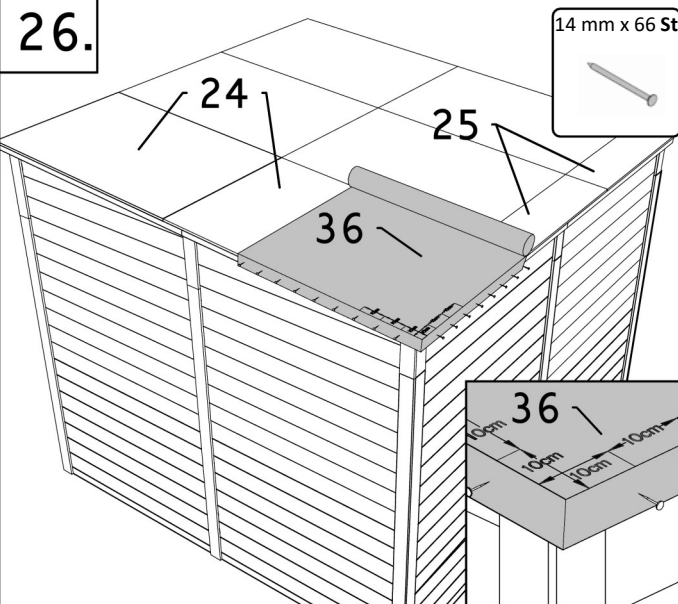

27.

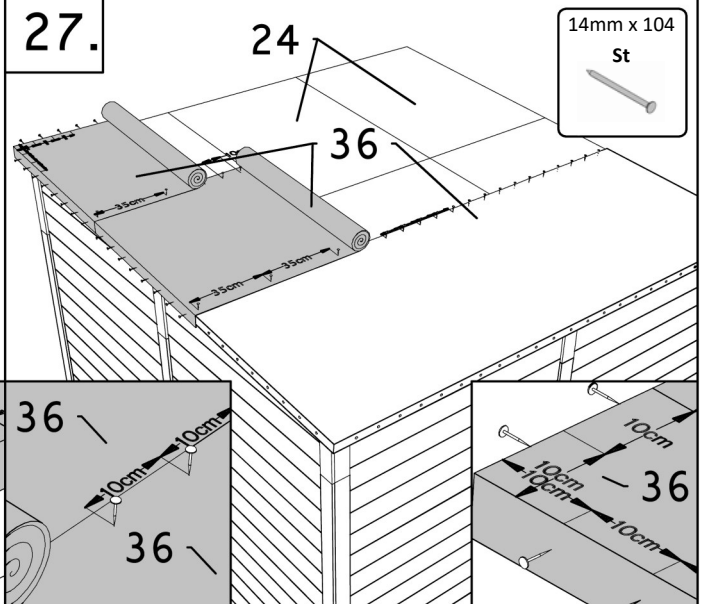

# OTALS8X8

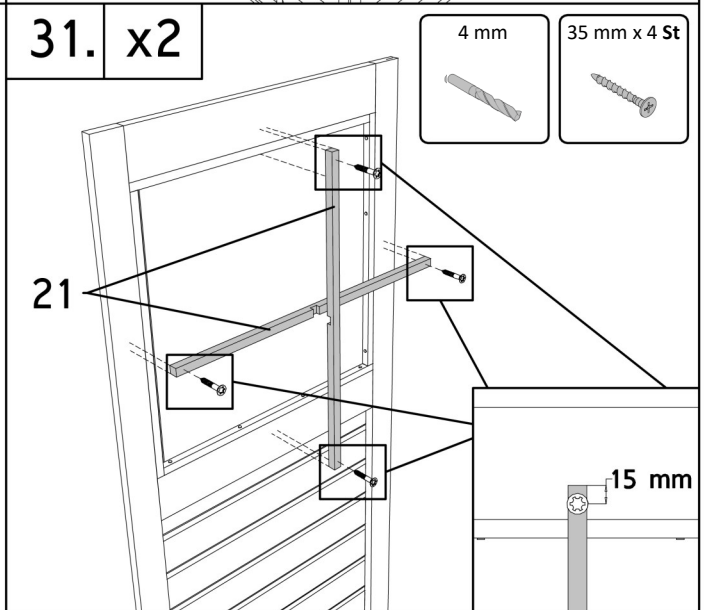
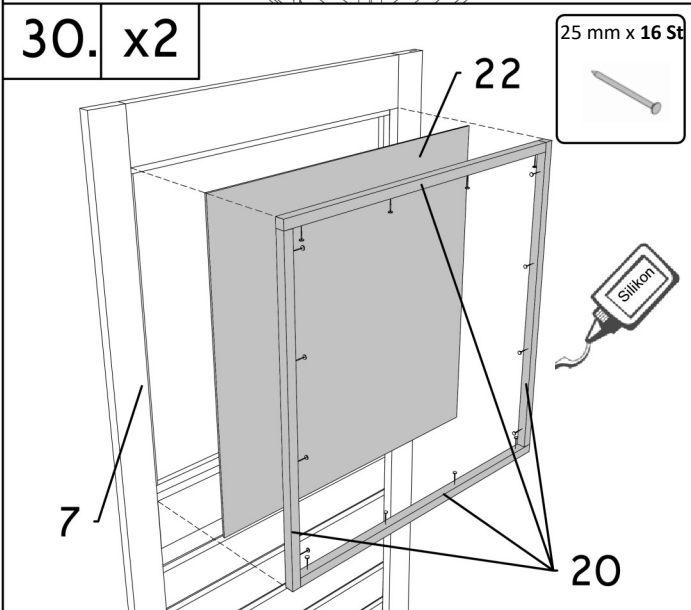
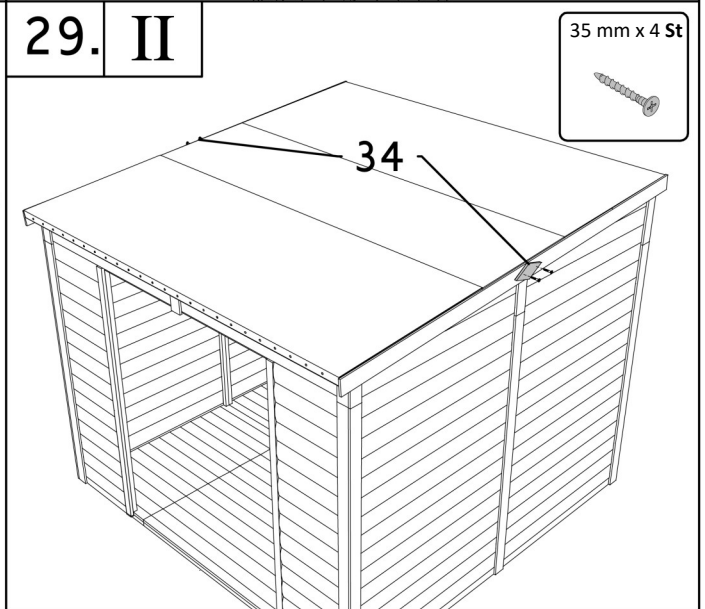
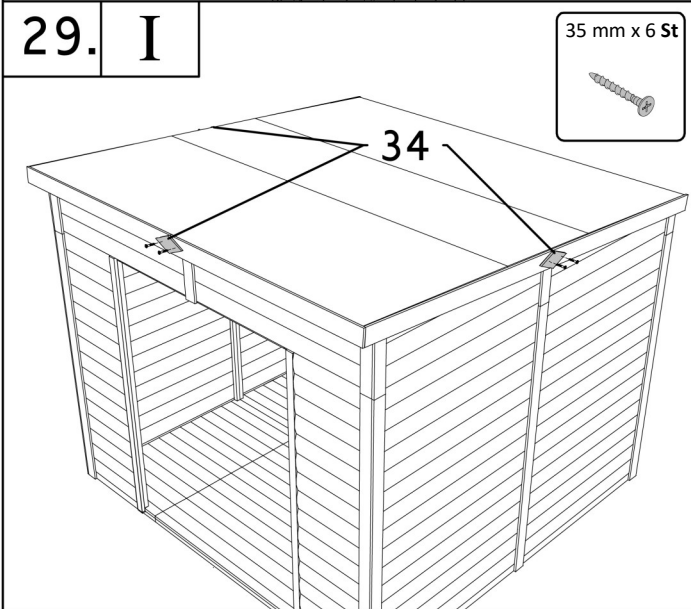
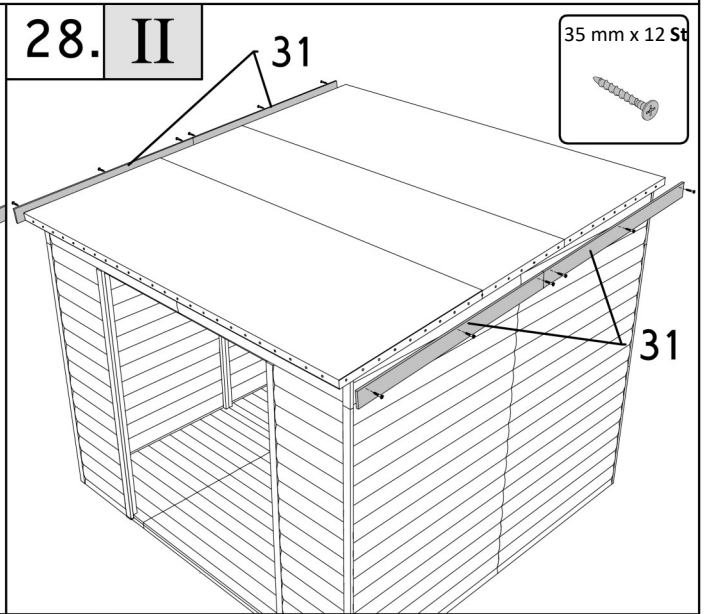
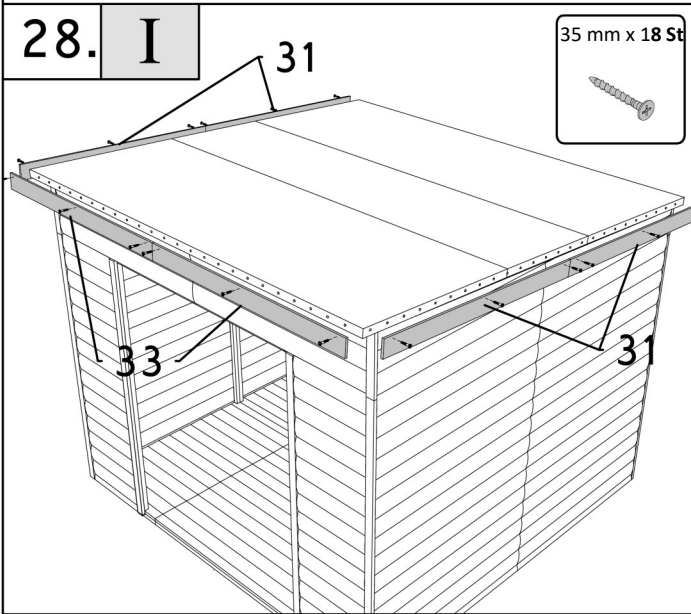

# OTALS8X8

